 **BD** FACSymphony™ A5 SE
Flow Cytometer
User's Guide

Copyrights

No part of this publication may be reproduced, transmitted, transcribed, stored in retrieval systems, or translated into any language or computer language, in any form or by any means: electronic, mechanical, magnetic, optical, chemical, manual, or otherwise, without prior written permission from BD.

The information in this guide is subject to change without notice. BD reserves the right to change its products and services at any time. Although this guide has been prepared with every precaution to ensure accuracy, BD assumes no liability for any errors or omissions, nor for any damages resulting from the application or use of this information. BD welcomes customer input on corrections and suggestions for improvement.

Trademarks

BD, the BD Logo, FACS, FACSClean, FACSDiva, FACSFlow, and FACSsymphony are trademarks of Becton, Dickinson and Company or its affiliates. All other trademarks are the property of their respective owners. © 2021 BD. All rights reserved.

Alexa Fluor™ is a trademark of Life Technologies Corporation.

Cy™ is a trademark of GE Healthcare. Cy™ dyes are subject to proprietary rights of GE Healthcare and Carnegie Mellon University, and are made and sold under license from GE Healthcare only for research and in vitro diagnostic use. Any other use requires a commercial sublicense from GE Healthcare, 800 Centennial Avenue, Piscataway, NJ 08855-1327, USA.

Regulatory information

For Research Use Only. Not for use in diagnostic or therapeutic procedures.

Laser safety information

Class 1 Laser Product.

FCC information

WARNING: Changes or modifications to this unit not expressly approved by the party responsible for compliance could void the user's authority to operate the equipment.

NOTICE: This equipment has been tested and found to comply with the limits for a Class A digital device, pursuant to Part 15 of the FCC Rules. These limits are designed to provide reasonable protection against harmful interference when the equipment is operated in a commercial environment. This equipment generates, uses, and can radiate radio frequency energy and, if not installed and used in accordance with the instruction manual, may cause harmful interference to radio communications. Operation of this equipment in a residential area is likely to cause harmful interference in which case the user will be required to correct the interference at his or her own expense. Shielded cables must be used with this unit to ensure compliance with the Class A FCC limits. This Class A digital apparatus meets all requirements of the Canadian Interference-Causing Equipment Regulations. Cet appareil numérique de la classe A respecte toutes les exigences du Règlement sur le matériel brouilleur du Canada.

History

Revision	Date	Change made
23-23473(01)	2021-06	Initial release

Contents

1 ABOUT THIS GUIDE	7
What this guide covers	8
Conventions	8
About the documentation	9
Instrument technical support	10
2 INTRODUCTION	11
System overview	12
Cytometer overview	12
Control panel	14
Fluidics system	15
Sheath and waste containers	19
Optics	20
Workstation	22
3 CYTOMETER SETUP	23
Starting the cytometer and computer	24
Preparing the sheath container	25
Removing air bubbles	27
Preparing the waste container	29
Preparing the fluidics	31
Adding a bead lot number	32
Custom configurations and baselines	34
4 MAINTENANCE	35
Maintenance overview	36
Cleaning the fluidics	37
Shutting down the cytometer	38
Flushing the system	38
Replacing the waste container cap	40

Changing the sheath filter	41
Changing the Bal seal	42
Changing the sample tube O-ring	44
Cleaning or replacing the sheath gasket	45
5 SPECTRAL FUNCTIONS	47
Spectral function overview	48
Autofluorescence	52
Spectral unmixing software considerations	53
Setting up a new spectral experiment	53
Setting up the Spectral Unmixing algorithm	56
Recording and analyzing spectral data	59
Repeating a spectral experiment	61
6 OPTIMIZING CYTOMETER SETTINGS	63
Cytometer settings workflow	64
Verifying the configuration and user preferences	65
Running a performance check	67
Setting up a compensation experiment	69
Creating application settings	72
Recording compensation controls	73
Calculating compensation	76
7 RECORDING AND ANALYZING DATA	77
Data recording and analysis workflow	78
Preparing the workspace	78
Recording data	79
Analyzing data	81
Reusing an analysis	84
8 MANUAL SETTINGS	87
About laser delay	88
Optimizing laser delay	88
Adjusting area scaling	90
9 TROUBLESHOOTING	95
Cytometer troubleshooting	96
Electronics troubleshooting	101
10 SUPPLIES AND CONSUMABLES	103
Ordering information	104
Beads	104
Reagents	105
Equipment	105

INDEX

107

This page intentionally left blank

1

About this guide

This chapter covers the following topics:

- [What this guide covers \(page 8\)](#)
- [Conventions \(page 8\)](#)
- [About the documentation \(page 9\)](#)
- [Instrument technical support \(page 10\)](#)

What this guide covers

This guide describes the procedures necessary to operate and maintain the BD FACSymphony™ A5 SE Special Order Research Product (SORP) flow cytometer.

Because many cytometer functions are controlled by BD FACSDiva™ software, this guide also contains information about software features required for basic cytometer setup and operation.





This guide assumes you have a working knowledge of basic Microsoft® Windows® operation. If you are not familiar with the Windows operating system, see the documentation provided with your computer.

Conventions

Introduction

The following table lists the safety symbols used in this guide to alert you to potential hazards.

Safety symbols

Symbol	Meaning
	Caution alert Identifies a hazard or unsafe practice that could result in data loss, material damage, minor injury, severe injury, or death
	Biological hazard
	Electrical hazard
	Laser hazard

About the documentation

Introduction

This topic describes the documentation available with the BD FACSymphony™ A5 SE flow cytometer.

The following list includes the available documentation for the system.

- *BD FACSDiva™ Software Reference Manual*: Includes instructions or descriptions for installation and setup, workspace components, acquisition controls, analysis tools, and data management. Access this manual from the BD FACSDiva™ Software Help menu (Help > Documentation > Reference Manual), or by double-clicking the shortcut on the desktop.
- *BD® Cytometer Setup and Tracking Application Guide*: Describes how to use the BD® Cytometer Setup and Tracking (CS&T) features in BD FACSDiva™ software.
- *BD FACSymphony™ A5 SE Flow Cytometer Site Preparation Guide* contains specifications for:
 - Cytometer weight and size
 - Temperature and other environmental requirements
 - Electrical requirements
- *BD FACSymphony™ A5 SE Flow Cytometer Safety and Limitations*: Provides descriptions of safety and warning labels, general system hazards, specific risks, and laser, electrical, and biological hazards.
- *BD® High Throughput Sampler User's Guide*: Describes how to set up and operate the BD® High Throughput Sampler (HTS) option. It also contains a description of BD FACSDiva™ software features specific to the HTS.
- *BD FACFlow™ Supply System User's Guide*: Describes the optional automated sheath and waste fluid control system.

Publication formats

This guide is provided in PDF format to provide an eco-friendly option.

Instrument technical support

Introduction

This topic describes how to get technical assistance.

Contacting technical support

If technical assistance is required, contact your local BD Biosciences customer support representative or supplier. Go to our website bdbiosciences.com for up-to-date contact information.

When contacting BD Biosciences, have the following information available:

- Product name, part number, and serial number
- Version of BD FACSDiva™ software you are using
- Any error messages
- Details of recent system performance

More information

- [What this guide covers \(page 8\)](#)

2

Introduction

This chapter covers the following topics:

- [System overview \(page 12\)](#)
- [Cytometer overview \(page 12\)](#)
- [Control panel \(page 14\)](#)
- [Fluidics system \(page 15\)](#)
- [Sheath and waste containers \(page 19\)](#)
- [Optics \(page 20\)](#)
- [Workstation \(page 22\)](#)

System overview

About the system

The BD FACSymphony™ A5 SE system includes the flow cytometer, BD FACSDiva™ software v9.3 or later (for Windows 10) running on the system workstation, the optional BD FACFlow™ supply system (FFSS), and the optional BD® High Throughput Sampler (HTS). Each component is described in detail in the following sections.

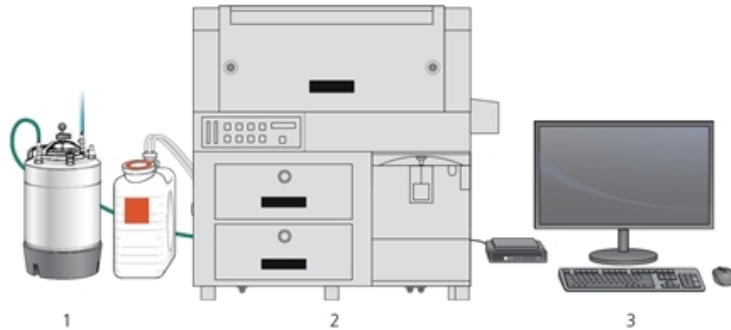

Number	Components
1	Sheath and waste tanks
2	BD FACSymphony™ A5 SE flow cytometer
3	Computer workstation

Cytometer overview

Introduction

The BD FACSymphony™ A5 SE flow cytometer is an air-cooled multi-laser benchtop instrument with the ability to acquire parameters for a large number of colors. It uses fixed-alignment lasers that transmit light through a flow cell to cascaded detector arrays. These detectors collect and translate the resulting fluorescence signals into electronic signals. Cytometer electronics convert these signals into digital data.

Components

The following figure shows the main components of the instrument. Each component is described in detail in the following sections.



Number	Component	Number	Component
1	Heat ventilation slots (top)	6	Sample injection port (SIP)
2	Control panel	7	Heat ventilation slots (side)
3	Power button	8	Air and fluidic ports
4	Electrical plug	9	Optics access doors (cacadagon detector arrays)
5	Fluidic sensors		



Caution! Do not place any objects on top of the instrument. Blocking the ventilation may cause the instrument to overheat.



Caution: Electrical Hazard! Do not place liquids on top of the instrument. Any spill of liquid into the ventilation openings could cause electrical shock or damage to the instrument.

Control panel

Overview

The following figure shows the components in the control panel, which are listed in the table.

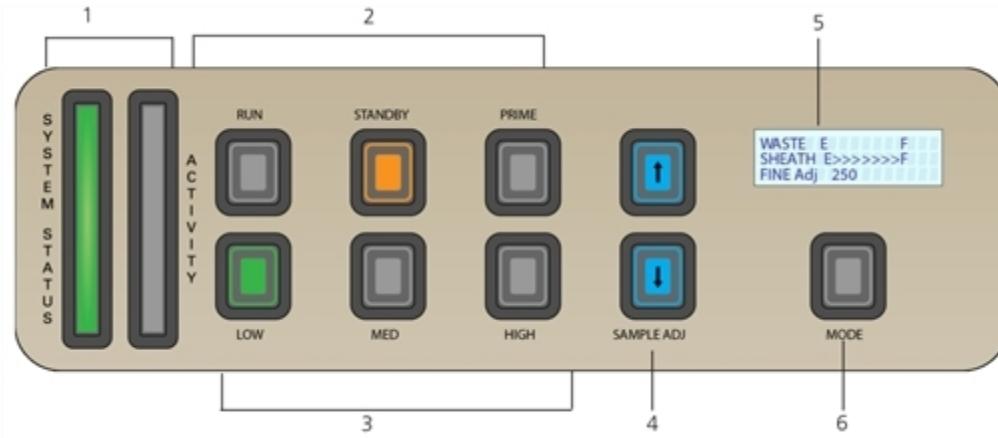

Number	Component
1	System indicators
2	Fluid control buttons
3	Sample flow rate buttons
4	Sample fine adjust buttons
5	Status screen
6	Mode button

More information

- [Fluidics system \(page 15\)](#)
- [Optics \(page 20\)](#)

Fluidics system



Introduction

The fluidics system carries the sample out of the sample tube and into the sensing region of the flow cell. Cells are carried in the sample core stream in single file and measured individually.

System indicators

There are two system indicators (System status and Activity) on the control panel.

- **System status.** Shows the status of the sheath and waste tank levels. The following table describes the LED indicators, conditions that trigger them, and any action that must be taken.

LED color	Status	Action
Green	Good	None
Yellow	 Caution! Sheath and waste tanks need attention.	Check tank levels
Red	 Caution! Take immediate action.	<ul style="list-style-type: none"> • Empty waste tank • Fill sheath tank

System status is also displayed on the Status screen. See [Status screen \(page 16\)](#) for a description of the Status screen.

- **Activity.** Shows whether the cytometer power is on and the status of acquisition. The following table describes the indicator LEDs, and the status that triggers them.

Indicator	LED color	Status
Steady pulse	Blue	Cytometer is powered on.
Fluctuates	Blue	Cells are passing through the flow cell.

Fluid control

The three fluid control buttons (Run, Standby, and Prime) set the cytometer operation.

- **Run** Pressurizes the sample tube to transport the sample through the sample injection tube and into the flow cell.

The Run button is green when the sample tube is on and the support arm is centered. When the tube support arm is moved left or right to remove a sample tube, the cytometer switches to an automatic standby status to conserve sheath fluid, and the Run button changes to orange.

- **Standby** Stops fluid flow to conserve sheath fluid.

When you leave the cytometer for more than a few minutes, place a tube containing 1 mL of deionized (DI) water on the sample injection port (SIP) and press Standby.

- **Prime** Prepares the fluidics system by draining and filling the flow cell with sheath fluid.

The fluid flow initially stops, and pressure is reversed to force fluid out of the flow cell and into the waste container. After a preset time, the flow cell fills with sheath fluid at a controlled rate to prevent bubble formation or entrapment. At completion, the cytometer switches to standby mode.

Sample flow rate control

The three flow rate control buttons (LOW, MED, HIGH) set the sample flow rate through the flow cell. The SAMPLE ADJ buttons allow you to adjust the rate to intermediate levels.

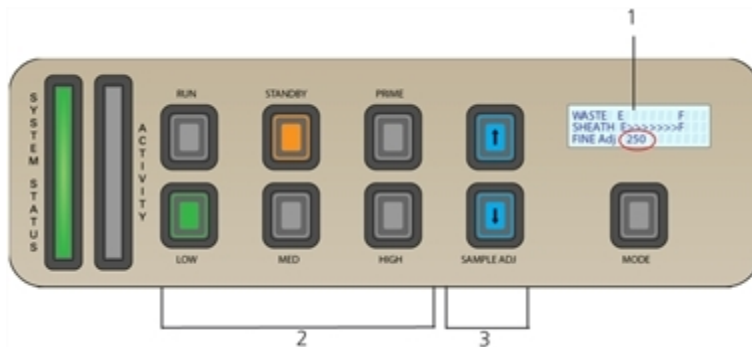

Number	Component
1	Status screen
2	Sample flow rate buttons
3	Sample fine adjust buttons

When sample adj is set at the midpoint of 250 (as shown on the status screen on the control panel) the sample flow rates at the low, med, and high settings are approximately 12, 35, and 60 $\mu\text{L}/\text{min}$ of sample, respectively. Each time you press one of the SAMPLE ADJ buttons, the fine adjust of the indicated sample increases or decreases by 10. The following table shows the approximate sample flow rate range for low, medium, and high.

Settings	Sample flow rate ($\mu\text{L}/\text{min}$)
Low	6–24
Med	17.5–70
High	30–120

Status screen

When not in FFSS mode, the first two lines of the status screen show the level of the waste and sheath tanks. The third line toggles between Fine Adj. and Air Pressure. Status is described in detail in the following table.



Item	Definition
1	Waste level. Shows range (1) from E (empty) to F (full). The display line increases from left to right in sequences of 20%. System status turns yellow at 80%, and red at 100% full.
2	Sheath level. Shows range from E to F. The display line decreases from right to left in sequences of 20% from full level. System status turns yellow at 20%, and red at 0%.
3	Fine Adj. Shows the current setting of fine adjust. Fine adjust can be set in increments of 10 from 0 to 500. The last value persists, even after cytometer shutdown.
	Air pressure. Shows the air pressure as either greater than (>) 5.4 psi, or less than (<) 5 psi. To display psi, press the Mode button, followed by the Up button.
4	FFSS Mode. Shows that the cytometer is in FFSS mode. To enter this mode, press the MODE button 4 times. After you reach FFSS OFF, push the SAMPLE ADJ button once. You should now see the panel display FFSS ON. To exit, press the MODE button 4 times, then SAMPLE ADJ button once. Repeat the process to turn FFSS mode off.

Fluidic alarms and the Mode button

The fluidic alarms are triggered by the waste and sheath fluid levels in the tanks. The alarms sound when the waste tank is nearly 100% full and the sheath tank is empty.

To silence the alarm, press the Mode button, then press the Down button. The Mode button flashes to indicate the cytometer is in silent mode. Repeat this sequence to turn off silent mode.

Note: When the cytometer is in FFSS mode, the alarms are deactivated.

Sample injection port

The SIP is where the sample tube is installed. The SIP includes the sample injection tube and the tube support arm. Samples are introduced through a stainless steel injection tube equipped with an outer droplet containment sleeve. The sleeve works in conjunction with a vacuum pump to eliminate droplet formation of sheath fluid as it backflushes from the sample injection tube.

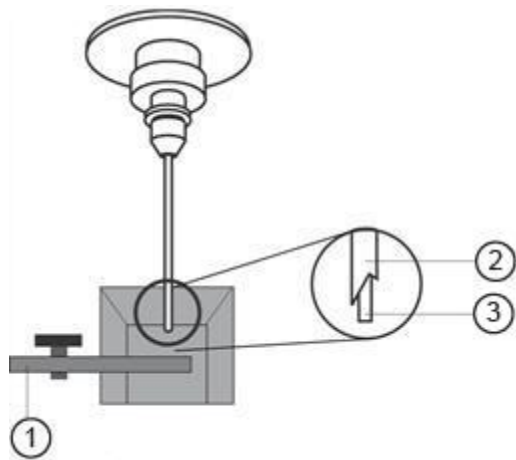

Key	Description
1	Tube support arm
2	Outer sleeve
3	Sample injection tube

Sample injection tube

Stainless steel tube that carries sample from the sample tube to the flow cell. This tube is covered with an outer sleeve that serves as part of the droplet containment system.

Tube support arm

Arm that supports the sample tube and activates the droplet containment system vacuum. The vacuum is on when the arm is positioned to the side and off when the arm is centered.

Note: If a sample tube is left on the SIP with the tube support arm to the side (vacuum on), the sample will be aspirated into the waste container.

Cautions when using the HTS option



Caution: Biohazard! When using the flow cytometers with the HTS, ensure that the HTS is completely pushed into the operating position before removing the droplet containment module (DCM) sleeve or disconnecting the sample coupler from the SIP. This is to avoid accidental leakage of potentially biohazardous liquids directly onto the instrument. With the HTS in the proper location, the containment dish with padding is directly below the SIP.



Caution! If you are using the HTS option, always slide the HTS mount slowly to prevent sample cross-contamination when the wells are full. Never move the HTS when it is in operation.



Caution! Do not lean on or put any weight on the HTS as it could damage the instrument.

Droplet containment module

The droplet containment module (DCM) prevents sheath fluid from dripping from the SIP and provides biohazard protection.

Note: The DCM will not run when the HTS selector switch is in Plate Mode.

When no sample tube is installed on the SIP, sheath fluid backflushes through the sample injection tube. This backflush helps prevent carryover of cells between samples. The DCM vacuum is activated when the sample tube is removed and the tube support arm is moved to the side. Sheath fluid is aspirated as it backflushes the sample injection tube.

Sheath and waste containers

Introduction

This topic describes the sheath and waste containers. The sheath and waste containers are outside the cytometer and are positioned on the floor. The sheath and waste containers should remain in the installed position. Moving them to a different height (for example, from the floor to a bench) changes the flow rate.

Note: If you are using the FFSS, see the *BD FACSTFlow™ Supply System User's Guide*.

Sheath container

The sheath container has a capacity of 10 L. Sheath fluid is filtered through an in-line, interchangeable filter that prevents small particles from entering the sheath fluid lines. An alarm sounds when the container is empty.



Caution! Do not fill the sheath tank to its maximum capacity. When an overfull tank is pressurized, erratic cytometer performance can result.

Waste container

The waste container has a capacity of 10 L. An alarm sounds when the container is full. If the waste container overfills, install a replacement waste tank cap and baffle.

More information

- [Preparing the sheath container \(page 25\)](#)
- [Preparing the waste container \(page 29\)](#)
- [Status screen \(page 16\)](#)
- [Fluidic alarms and the Mode button \(page 17\)](#)

Optics

Introduction

This topic describes the optical components for the BD FACSymphony™ A5 SE flow cytometer including:

- Detector arrays
- Laser options
- Optical filters
- Signal detectors

Detector arrays

The detector arrays consist of cascaded arrays. Each cascaded array is outfitted with 2 to 20 PMTs and can detect the corresponding number of signals.

Laser options

The flow cytometers can be configured with up to 10 lasers. The following table lists the lasers:

Laser	Wavelength (nm)	Power (mW)
Violet	405	200
Blue	488	150
UV	355	60
Yellow Green	561	150
Red	637	140

Optical filters

Optical filters attenuate light or help direct it to the appropriate detectors. The name and spectral characteristics of each filter appear on its holder.

There are two types of optical filters in the BD FACSymphony™ A5 SE flow cytometer:

- **Longpass dichroic mirrors (LPs)** Transmit wavelengths that are longer than the specified value and reflect all light below the specified wavelength.
- **Bandpass filters (BPs)** Pass a narrow spectral band of light.

When dichroic filters are used as steering optics to direct different color light signals to different detectors, they are called dichroic mirrors. LP dichroic mirrors transmit longer wavelengths to one detector while reflecting shorter wavelengths to a different detector.

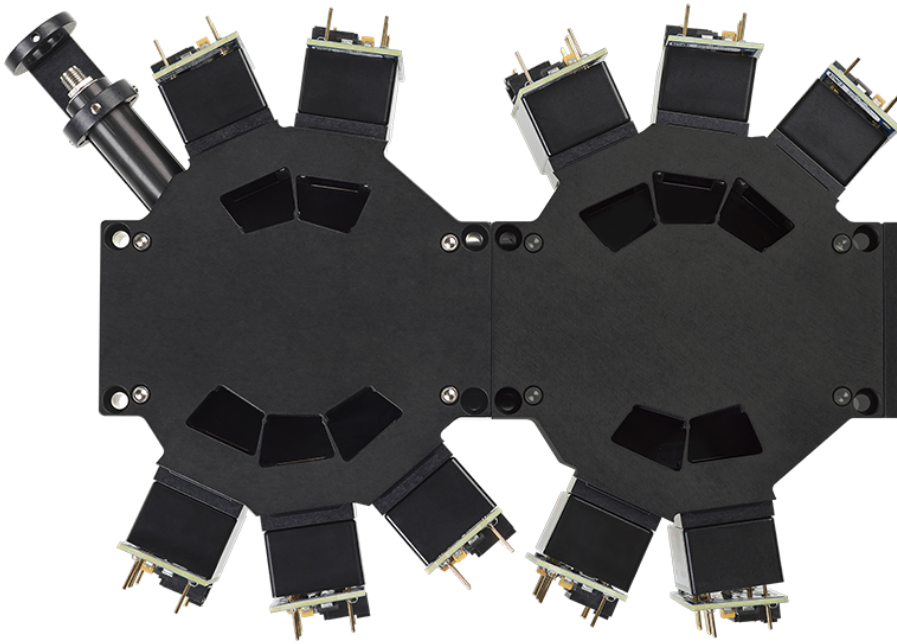

Signal detectors

Particles in the fluid stream passing through the laser beam absorb energy and are excited to emit photons at discrete lower frequencies. When these photons reach a detector, electrical pulses are created that are then processed by the electronics system.

There are two types of signal detectors in the BD FACSymphony™ A5 SE flow cytometer:

- **PMTs** Used to detect the weaker signals generated by side scatter (SSC) and all fluorescence channels. These signals are amplified by applying a voltage to the PMTs.
- **Photodiodes.** Less sensitive to light signals than the PMTs. A photodiode is used to detect the stronger forward scatter (FSC) signal.

Laser/Detector/Mirror/Filter Combinations

Each PMT has an optic holder in front of it. The optic holders are labeled with numbers indicating the wavelengths of the bandpass filter and longpass dichroic mirror they contain (for example, 780/60 and 750 LP, respectively). The optic holder in front of the last PMT in the detector array contains only a bandpass filter and is marked accordingly.

Base configurations

Each flow cytometer has a base cytometer configuration that corresponds to the layout of the installed lasers and optics in your cytometer. This base configuration is factory set.

Cytometer configuration in BD FACSDiva™

BD FACSDiva™ software provides a base configuration for your flow cytometer. In the case of the BD FACSymphony™ A5 SE flow cytometer, the base configuration corresponds to the fixed configuration for the spectral function. For details, see [Spectral Functions \(page 47\)](#). Select **Cytometer > View Configuration** to create, modify or delete custom configurations for compensation cytometry. (See the Cytometer and Acquisition Controls chapter of the *BD FACSDiva™ Software Reference Manual*.)

Workstation

Introduction

This topic describes the components of the workstations.

Workstation components

Acquisition, analysis, and most instrument functions are controlled by the workstations. They include a PC and one or two monitors. Your workstation is equipped with the following:

- Microsoft Windows operating system
- BD FACSDiva™ software version 9.3 or later for Windows 10 for data acquisition and analysis
- Software documentation including the help system accessible from a menu in the BD FACSDiva™ software.

3

Cytometer setup

This chapter covers the following topics:

- [Starting the cytometer and computer \(page 24\)](#)
- [Preparing the sheath container \(page 25\)](#)
- [Removing air bubbles \(page 27\)](#)
- [Preparing the waste container \(page 29\)](#)
- [Preparing the fluidics \(page 31\)](#)
- [Adding a bead lot number \(page 32\)](#)
- [Custom configurations and baselines \(page 34\)](#)

Starting the cytometer and computer

Introduction

This topic describes how to start the cytometer and turn on the computer.

Note: If your system is using the FFSS, make sure that the FFSS is powered on before the cytometer.

Procedure

To start the cytometer:

1. Turn on the power to the flow cytometer.
2. Turn on the computer and log in to Windows.

Note: You can turn on the power to the flow cytometer and the workstation in any order.

3. Turn on the lasers.
4. Allow 30 minutes for the optical system temperature to stabilize.



Caution! Failure to warm up and stabilize the instrument could affect sample data.

5. Start BD FACSDiva™ software by double-clicking the shortcut on the desktop, and log in to the software.
6. Check the Cytometer window in BD FACSDiva™ software to ensure that the cytometer is connected to the workstation.

The cytometer connects automatically. While connecting, the message “Cytometer Connecting” is displayed in the status area of the Cytometer window. When connection completes, the message changes to “Cytometer Connected.”

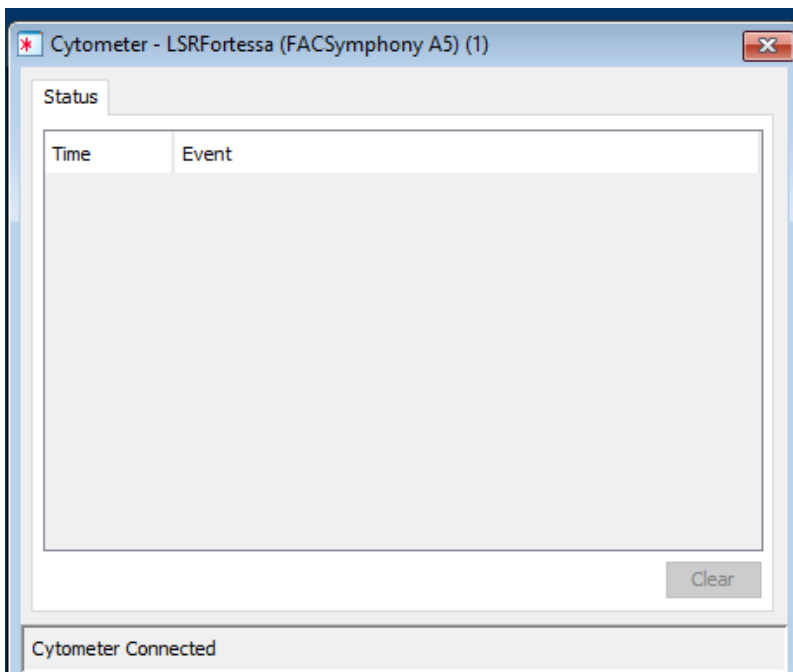

If the message does not change from “Cytometer Connecting”, see [Electronics troubleshooting \(page 101\)](#).

Preparing the sheath container

Introduction

This topic describes how to prepare the sheath container.

Note: If your system is using the FFSS, see the *BD FACSTlow™ Supply System User's Guide*.

When to check the sheath and waste containers

Check the fluid levels in the sheath container and waste container every time you use the cytometer. This ensures that you do not run out of sheath fluid during an experiment and that the waste container does not overflow.

Sheath container components

The sheath container components are shown in the following image:

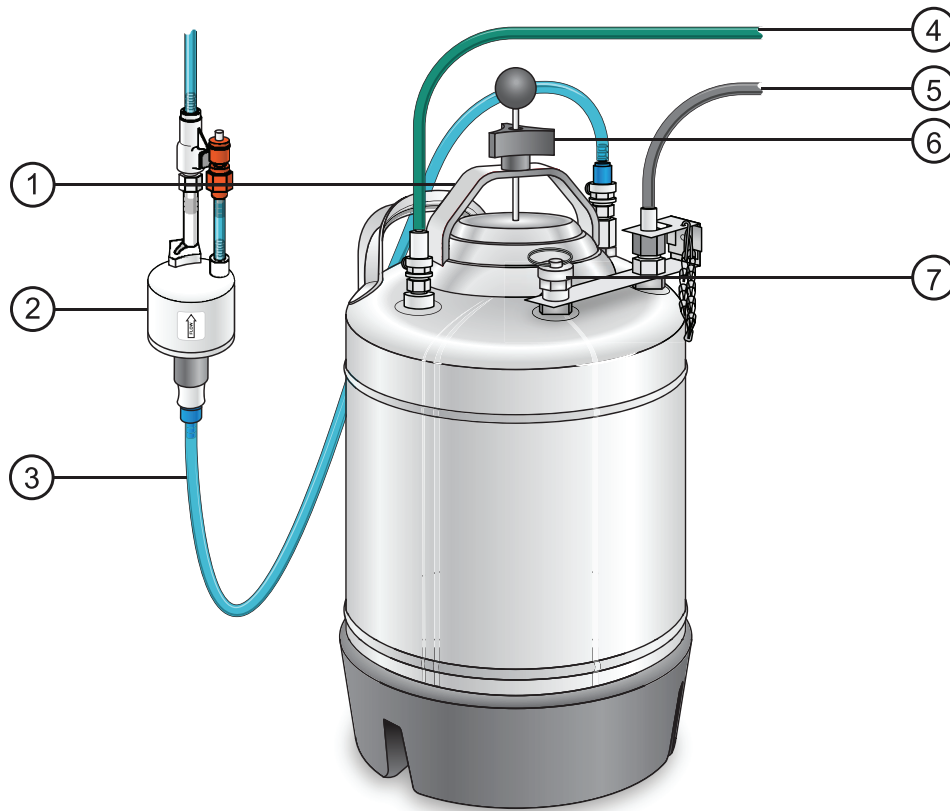

Item Number	Component
1	Cap handle
2	Filter assembly
3	Sheath fluid line (blue) to flow cytometer
4	Air line (green)
5	Alarm sensor
6	Clamp knob
7	Vent valve

Procedure

To prepare the sheath container:

1. Verify that the flow cytometer is in standby mode.
Press the **STANDBY** button on the control panel if necessary.
2. Disconnect the green air line, sheath fluid line, and alarm sensor from the sheath container.
3. Depressurize the sheath container by pulling up on the vent valve.

4. Remove the sheath container lid.
Unscrew the clamp knob and push down to loosen, if necessary. Tilt the cap to the side to remove it from the tank.
5. Add 10 L of sheath fluid, such as BD FACSTFlow™ solution, to the sheath container.
Note: The 10 L will reach the interior line on the sheath tank. Do not fill the sheath tank further.
6. Replace the sheath container lid.
7. Reconnect the green air line and the alarm line.
8. Make sure the gasket on the inside lip of the sheath lid is seated correctly and has not slipped out of position.
If the gasket is not seated correctly, the tank will not pressurize properly.
9. Close the sheath lid and tighten the clamp knob to finger-tight. Ensure that the blue sheath fluid line is not kinked.

More information

- [Removing air bubbles \(page 27\)](#)
- [Changing the sheath filter \(page 41\)](#)
- [Cleaning or replacing the sheath gasket \(page 45\)](#)

Removing air bubbles

Introduction

This topic describes how to remove trapped air bubbles in the sheath filter and the sheath line. Air bubbles can occasionally dislodge and pass through the flow cell, resulting in inaccurate data.

Note: Perform this activity every time the sheath tank is refilled.

Procedure

To remove air bubbles:

1. Check the sheath filter for trapped air bubbles.

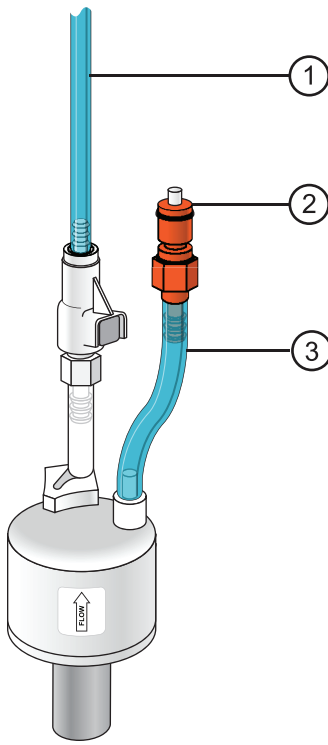

Item Number	Component
1	Flow cytometer fluid line (roller clamp not visible)
2	Vent fitting
3	Vent line

2. If bubbles are visible, gently tap the filter body with your fingers to dislodge the bubbles and force them to the top.



Caution! When removing air bubbles, do not vigorously shake, bend, or rattle the sheath filter or you might damage it.

- Direct the vent line into a beaker and press the small button at the end of the vent fitting against the side of the beaker until a steady stream of fluid empties from the filter.

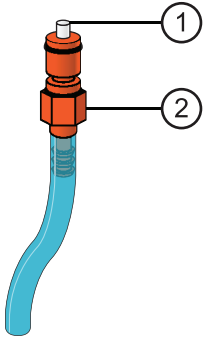

Item Number	Component
1	Button
2	Vent fitting

- Tilt the filter and verify that no trapped air remains in the filter.
- Repeat steps 3 and 4 until no air is observed in the filter.
- Check the sheath line for air bubbles.
- Open the roller clamp at the fluidics interconnect (if necessary) to bleed off any air in the line. Collect any excess fluid in a waste container.
- Close the roller clamp.

Preparing the waste container

Introduction

This topic describes how to prepare the waste container. Prevent waste overflow by emptying the waste container daily or whenever the system status indicator turns yellow.

Note: If your system is connected to the FFSS, see the documentation provided with your FFSS.



Caution: Biohazard! All biological specimens and materials coming into contact with them are considered biohazardous. Handle as if capable of transmitting disease. Dispose of waste using proper precautions and in accordance with local regulations. Never pipette by mouth. Wear suitable protective clothing, eyewear, and gloves.

Waste container components

The following figure shows the main components of the waste container.

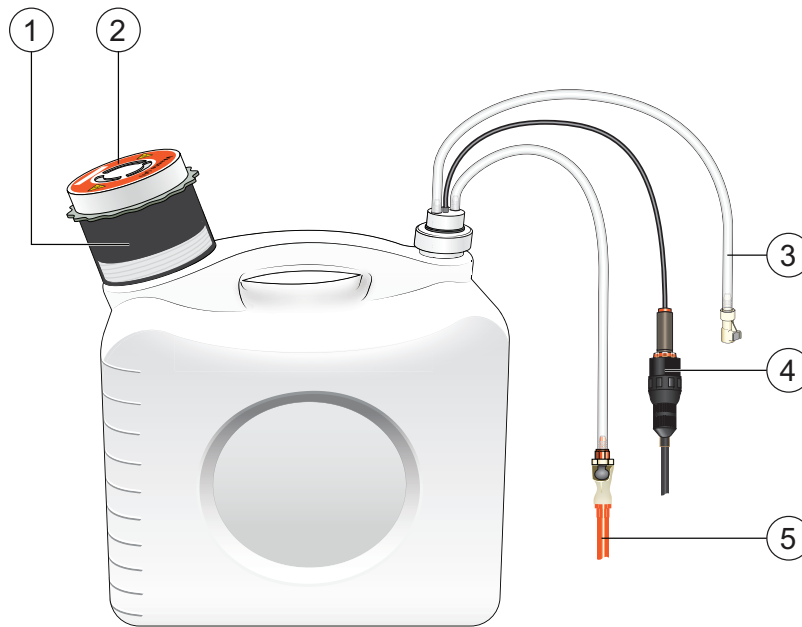

Item Number	Component
1	Baffle
2	User-replacable cap
3	Air line
4	Alarm sensor
5	Waste fluid line with clip

Biological precautions



Caution: Biohazard! Contact with biological specimens and materials can transmit potentially fatal disease.

To prevent exposure to biohazardous agents:

- Put the flow cytometer in standby mode before disconnecting the waste tank, to avoid leakage of biohazardous waste.
- Always disconnect the waste tank from the flow cytometer before you empty it. Wait at least 30 seconds for pressure to dissipate before you remove the waste cap or sensor.
- Expose waste tank contents to bleach (10% of total volume) for 30 minutes before disposal.
- Do not wet the waste tank cap. If wet, the filter in the cap will cause the tank to malfunction. To keep the cap dry, place it on the bench label-side up when it is not on the tank.
- If the waste tank overflows always install a replacement waste tank cap and baffle.

Procedure

To prepare the waste container:

1. Verify that the flow cytometer is in standby mode.
Press the STANDBY button on the control panel if necessary.
2. Disconnect the orange waste tubing and the black alarm sensor line from the waste container.
Keep the lid on the waste container until you are ready to empty it.
3. Empty the waste container.



Caution! The waste container is heavy when full. When emptying it, use good body mechanics to prevent injury.

4. Add approximately 1 L of bleach to the waste container and close it.
5. Reconnect the orange waste tubing and make sure it is not kinked.
6. Reconnect the black alarm sensor line.

Preparing the fluidics

Introduction

This topic describes how to prepare the fluidics system.

When to prime the fluidics

Sometimes, air bubbles and debris may become lodged in the flow cell. This is indicated by excessive noise in the forward and side scatter parameters (FSC and SSC, respectively). In these cases, it is necessary to prime the fluidics system. Priming introduces air to the flow cell. Following the procedures below minimize the need for priming and make priming more effective when needed.

Procedure

Start up the fluidics:

1. Turn on the computer and instrument as described in [Starting the cytometer and computer \(page 24\)](#).
2. Install a tube with 3 mL of 1.5% dilution of BD[®] Detergent Solution Concentrate on the SIP and put the tube support arm underneath the tube.

Note: The BD[®] Detergent Solution Concentrate must be diluted before use. Mix one full 15 mL bottle of BD[®] Detergent Solution Concentrate into 985 mL of DI water to make 1 L total.

3. Press RUN and HIGH on the cytometer fluid control panel. Run for 10 minutes.
4. Remove the tube of detergent from the SIP and replace with a tube containing 3 mL of DI water.
5. Again, press RUN and HIGH on the cytometer fluid control panel. Run for 10 minutes.

Determine whether or not the fluidics need to be debubbled by priming:

1. Open or create an experiment to view BD[®] CS&T Beads. For details, see [Running a performance check \(page 67\)](#) and [Setting up a compensation experiment \(page 69\)](#).
2. Press RUN and LOW on the cytometer fluid control panel.

3. Observe the plots for the scatter channel and fluorescent channels. There should be two distinct peaks for each scatter channel and three distinct peaks for each fluorescent channel. The coefficient of variation (CV) for bright peaks should be narrow. If either the CVs are very wide on a detector or no signal is observed, the fluidics need to be primed as described in the following procedure.

To prime the fluidics:

1. Move the tube support arm to the side.
2. Remove the tube from the SIP or leave the HTS connected to the SIT.
3. Press the PRIME fluid control button to force the fluid out of the flow cell and into the waste container. Once drained, the flow cell automatically fills with sheath fluid at a controlled rate to prevent bubble formation or entrapment. The STANDBY button turns amber after completion.
4. When the STANDBY light is on, install a test tube of DI water or leave the HTS connected to the SIT.
5. Press the RUN fluid control button and run for 10 seconds.
6. Press the PRIME button immediately followed by the RUN button.
7. Repeat step 6 ten times.

If more than 2 seconds pass between PRIME and RUN in step 6, restart the procedure.

8. Install a 12 × 75 mm tube with 1 mL of DI water on the SIP and place the support arm under the tube. Leave the cytometer in standby mode.

More information

- [Cytometer troubleshooting \(page 96\)](#)

Adding a bead lot number

You need to be an administrator to perform this procedure.



Do not import a bead lot file as described in the *BD® Cytometer Setup and Tracking Application Guide* as the standard bead lot files are not applicable to the BD FACSymphony™ A5 SE flow cytometer. Use the following procedure to add a bead lot number instead.

Procedure

To add a bead lot number:

1. Select **Cytometer > CST**.
2. In the CS&T workspace, select **Tools > Bead Lots**.
The Bead Lots dialog opens.
3. Click **New**.
4. Enter the 6-digit part number for the BD® Cytometer Setup and Tracking Beads.
5. Enter the bead lot number.

6. Enter the expiration date.

Bead Lots [X]

Setup Beads

Lot IDs

- 11087 (RUO)

Bead Product:
CST Setup Beads

Part #:
642412

Lot ID:
11087

Expiration Date:
08-31-2022

No information is available for this bead lot.
Please contact BD support.

New Delete

Import Scan OK Cancel

7. Click **OK**.

Custom configurations and baselines

Introduction

This topic describes where to find information on how to create a custom configuration and define a baseline for a performance check.

Overview

BD® Cytometer Setup Software (CS&T) software is used to define the baseline performance of your cytometer. A baseline provides a starting point for the tracking of cytometer performance. When running a performance check, you compare the results to the baseline.

See [Optimizing cytometer settings \(page 63\)](#). See the latest published filter guides available on our website (bdbiosciences.com) for more information.

See the *BD Cytometer Setup and Tracking Application Guide* for information about creating custom configurations and defining a baseline.

More information

- [Running a performance check \(page 67\)](#)

4

Maintenance

This chapter covers the following topics:

- [Maintenance overview \(page 36\)](#)
- [Cleaning the fluidics \(page 37\)](#)
- [Shutting down the cytometer \(page 38\)](#)
- [Flushing the system \(page 38\)](#)
- [Replacing the waste container cap \(page 40\)](#)
- [Changing the sheath filter \(page 41\)](#)
- [Changing the Bal seal \(page 42\)](#)
- [Changing the sample tube O-ring \(page 44\)](#)
- [Cleaning or replacing the sheath gasket \(page 45\)](#)

Maintenance overview

Introduction

This topic provides an overview of the flow cytometer routine maintenance and cleaning procedures.

General use guidelines



Caution: Biohazard! Contact with biological specimens and materials can transmit potentially fatal disease.

Follow these guidelines whenever operating or maintaining the cytometer:

- Wear suitable protective clothing, eyewear, and gloves.
- Handle all biological specimens and materials in accordance with applicable regulations and manufacturer specifications.
- Dispose of waste using proper precautions and in accordance with local regulations.
- Never pipette by mouth.

For fluidics maintenance, we recommend the following cleaning solutions:

- BD FACSClean™
- BD® Detergent Solution Concentrate
- 10% bleach solution

Use DI water to dilute bleach to appropriate concentrations.



Caution! Higher concentrations of sodium hypochlorite and use of other cleaning solutions might damage the cytometer.

When to perform maintenance procedures

Perform maintenance procedures in the following frequencies.

Frequency	Maintenance procedure
Daily	<ul style="list-style-type: none"> • Cleaning the fluidics (page 37) • Shutting down the cytometer (page 38)
Scheduled (every two weeks)	<ul style="list-style-type: none"> • Flushing the system (page 38)
Periodic (frequency depends on how often you run the cytometer)	<ul style="list-style-type: none"> • Changing the sheath filter (page 41) • Changing the Bal seal (page 42) • Changing the sample tube O-ring (page 44) • Cleaning or replacing the sheath gasket (page 45)

Cleaning the fluidics

Introduction

This topic describes how to perform the daily fluidics cleaning.

Overview

Cleaning the fluidics daily prevents the sample injection tube from becoming clogged and removes dyes that can remain in the tubing.

In addition to daily cleaning, follow this procedure immediately after running viscous samples or nucleic acid dyes such as Hoechst, DAPI, propidium iodide (PI), acridine orange (AO), or thiazole orange (TO).

Procedure

To clean the fluidics:

1. Press RUN and HIGH on the cytometer fluid control panel.
2. Install a tube containing 3 mL of a cleaning solution on the SIP with the support arm to the side (vacuum on) and let it run for 1 minute.

For the cleaning solution, use BD FACSClean™ solution. See [Maintenance overview \(page 36\)](#) for other recommended cleaning solutions.

3. Move the tube support arm under the tube (vacuum off) and allow the cleaning solution to run for 5 minutes with the sample flow rate set to HIGH.
4. Repeat steps 2 and 3 with DI water.
5. Repeat steps 2 and 3 with 1.5% dilution of BD® Detergent Solution Concentrate.

Note: The BD® Detergent Solution Concentrate must be diluted before use. Mix one full 15 mL bottle of BD® Detergent Solution Concentrate into 985 mL of DI water to make 1 L total.



Caution! Do not mix BD® Detergent Solution Concentrate and bleach because they produce chlorine gas.

6. Repeat steps 2 and 3 with DI water.
7. Press the STANDBY button on the fluidics control panel.
8. Place a tube containing no more than 1 mL of DI water on the SIP.

A tube with 1 mL of DI water should remain on the SIP to prevent salt deposits from forming in the injection tube. This tube also catches back drips from the flow cell.



Caution! Do not leave more than 1 mL of water on the SIP. When the instrument is turned off or left in standby mode, a small amount of fluid will drip back into the sample tube. If there is too much fluid in the tube, it could overflow and affect the cytometer performance.

Shutting down the cytometer

Introduction

This topic describes how to shut down the cytometer.

Before you begin

Each time you shut down the cytometer, perform the daily cleaning as described in [Cleaning the fluidics \(page 37\)](#).

Procedure

To shut down the cytometer:

1. Place a tube of DI water on the SIP.
2. Turn off the flow cytometer.
3. Select **Start > Shutdown** to turn off the computer (if needed).
4. If your system is connected to the FFSS, shut off the FFSS.

If the cytometer will not be used for a week or longer, perform a system flush and leave the fluidics system filled with DI water to prevent saline crystals from clogging the fluidics.

More information

- [Cleaning the fluidics \(page 37\)](#)
- [Flushing the system \(page 38\)](#)

Flushing the system

Introduction

This topic describes how to perform an overall fluidics cleaning to remove debris and contaminants from the sheath tubing, waste tubing, and flow cell. Perform the system flush at least every 2 weeks.

Note: After installation of a new system or major repair of the fluidics system, perform a system flush with overnight soak twice a week for one month.

Note: If you are using the FFSS, see the *BD FACFlow™ Supply System User's Guide* for instructions on flushing the system.

Cautions



Caution: Biohazard! The cytometer hardware might be contaminated with biohazardous material. Use 10% bleach to decontaminate the instrument.

Procedure

To perform a system flush:

1. Remove the sheath filter.
 - a. Press the quick-disconnects on both sides of the filter assembly.
 - b. Remove the filter assembly.
 - c. Connect the two fluid lines.



Caution! Do not run detergent, bleach, or ethanol through the sheath filter. They can break down the filter paper within the filter body, causing particles to escape into the sheath fluid, possibly clogging the flow cell.

2. Empty the sheath container and rinse it with DI water.
 3. Fill the sheath container with at least 1 L of undiluted BD FACSClean™ solution.
 4. Empty the waste container, if needed.
 5. Open the roller clamp by the fluidics interconnect, and drain the fluid into a beaker for 5 seconds.
 6. Remove the DI water tube from the SIP.
 7. Prime the instrument twice:
 - a. Press the PRIME button on the fluidics control panel.
 - b. When the STANDBY button lights (amber), press the PRIME button again.
 8. Install a tube with 3 mL of undiluted BD FACSClean™ solution on the SIP and put the tube support arm underneath the tube.
- See [Maintenance overview \(page 36\)](#) for other recommended cleaning solutions.
9. Press RUN and HIGH on the cytometer fluid control panel. Run for 30 minutes.
 10. Press the STANDBY fluid control button and depressurize the sheath container by lifting the vent valve.
 11. Empty the waste container to avoid the mixing of bleach and BD® Detergent Solution Concentrate.



Caution! Do not mix BD® Detergent Solution Concentrate and bleach because they produce chlorine gas.

12. Repeat steps 2 through 10 with 1.5% dilution of BD® Detergent Solution Concentrate.

Note: The BD® Detergent Solution Concentrate must be diluted before use. Mix one full 15 mL bottle of BD® Detergent Solution Concentrate into 985 mL of DI water to make 1 L total.

13. Leave the system filled with 1.5% dilution of BD® Detergent Solution Concentrate overnight to soak (if possible, up to 18 hours) to reduce air adhesion throughout the system. When soaking, the system power should be disconnected and secured. Upon completion of the soak period, restore power and continue to the next step in this procedure .
14. Repeat steps 2 through 10 with DI water.
15. Replace the sheath filter and refill the sheath container with sheath fluid.

Replacing the waste container cap

Introduction

This topic describes how to replace the waste container cap. Replace the cap once a month.

Biological precautions



Caution: Biohazard! Contact with biological specimens and materials can transmit potentially fatal disease.

To prevent exposure to biohazardous agents:

- Put the cytometer in standby mode before disconnecting the waste tank to avoid leakage of biohazardous waste.
- The waste container can become pressurized when the cytometer is running. Always disconnect the waste container from the cytometer before you empty it. Wait at least 30 seconds for pressure to dissipate before you remove the waste cap or sensor.
- Expose waste container contents to bleach (10% of total volume) for 30 minutes before disposal.

Procedure

To replace the cap:

1. Put the cytometer in standby mode.
2. Disconnect the waste container's sensor line and orange waste line from the waste container tank, and wait at least 30 seconds for pressure to dissipate.
3. Remove the waste cap and attached baffle from the container and place on the bench label-side up.
4. Detach the cap from the baffle. If there is fluid in the baffle, replace it with a new one.
5. Place a new cap on the baffle.
6. Write the date on the cap label.

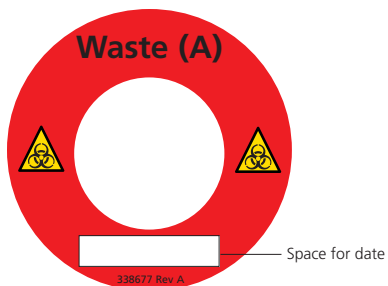

7. Screw the cap assembly onto the waste container and hand-tighten until it is fully closed.



Caution: Biohazard! To prevent waste container overpressurization, do not overtighten the trap or attached filter cap. Tighten each component only until it is hand-tight. Do not use sealants such as Teflon® tape or other adhesives.

Re-attach the alarm sensor line and waste line to the waste container tank.

Changing the sheath filter

Introduction

This topic describes how to change the sheath filter. The sheath filter is connected in-line with the sheath line. It filters the sheath fluid as it comes from the sheath container.

When to change the sheath filter

We recommend changing the sheath filter assembly every six months. Increased debris appearing in an FSC vs SSC plot can indicate that the sheath filter needs to be replaced. See [Supplies and consumables \(page 103\)](#) for ordering information.

Sheath filter components

The following illustration shows the sheath filter components.

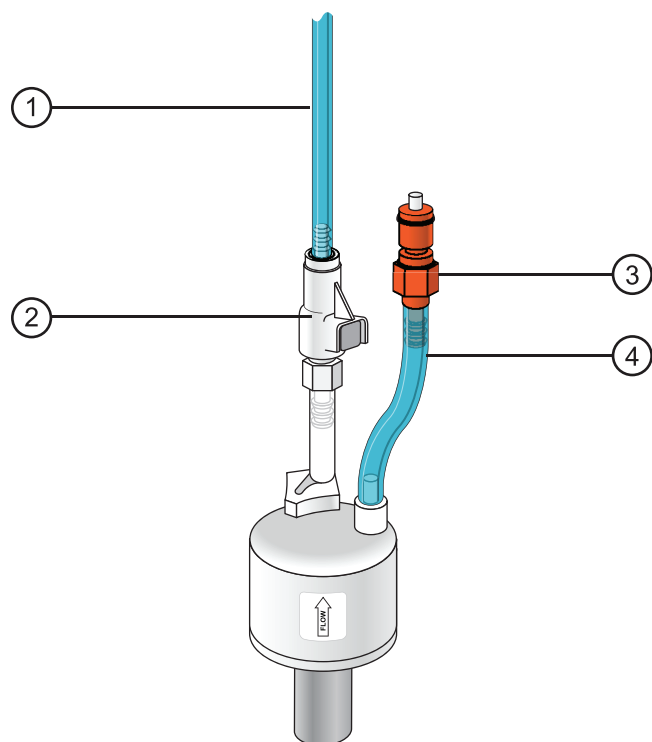

Item Number	Component
1	Sheath line
2	Quick disconnect
3	Vent fitting
4	Filter base

Removing the old filter

To remove the old filter:

1. Place the cytometer in standby mode.
2. Remove the sheath filter assembly by pressing the quick-disconnect on both sides of the filter assembly.
3. Over a sink or beaker:
 - Remove the vent line from the filter and set it aside.
 - Remove the filter base and set it aside.
4. Discard the used filter assembly in an appropriate receptacle.

Attaching the new filter

To attach the new filter:

1. Connect the vent line to the new filter assembly.
Twist to attach.
2. Wrap Teflon tape around the filter threads, then connect the filter to the filter base.
3. Connect the sheath line to the filter assembly by squeezing the quick-disconnect.
4. Attach the cytometer fluid line to the filter assembly via the quick-disconnect.
5. Direct the vent line into a beaker and press the small button at the end of the vent fitting against the side of the beaker until a steady stream of fluid empties from the filter.
6. Tilt the filter and verify that no trapped air remains in the filter.
7. Repeat steps 5 and 6 as necessary to remove all trapped air.

Changing the Bal seal

Introduction

This topic describes how to replace the Bal seal.

The sample injection tube Bal seal is a ring that forms a seal with the sample tube and ensures proper tube pressurization.

When to change the Bal seal

Over time, the Bal seal becomes worn or cracked and requires replacement. Replacement is necessary if a proper seal is not formed when a sample tube is installed on the SIP. Indications that a proper seal has not formed include:

- The tube will not stay on the SIP without the tube support arm.
- When the tube is installed and RUN is pressed on the cytometer, the RUN button is orange (not green).

Procedure

To replace the Bal seal:

1. Remove the outer sleeve from the sample injection tube by turning the retainer counterclockwise. Slide the outer sleeve down and off of the sample injection tube.

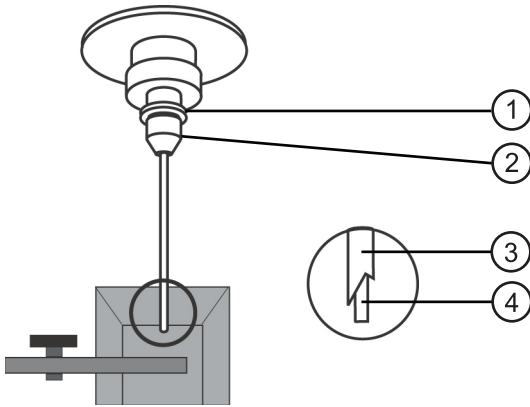

Item Number	Component
1	Bal seal
2	Retainer
3	Outer sleeve
4	Sample injection tube

Work carefully. The outer sleeve can fall off as you loosen the retainer.

2. Remove the Bal seal by gripping it between your thumb and index finger and pulling down.

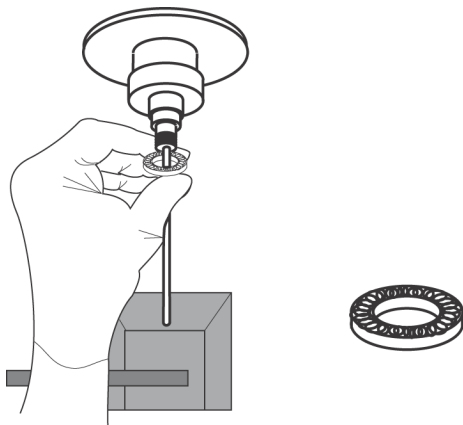

3. Install the new Bal seal spring-side up.
Ensure that the sample tube O-ring is still in place inside the retainer.
4. Re-install the retainer and outer sleeve over the sample injection tube. Push the outer sleeve all the way up into the sample injection port and then screw the retainer into place and tighten to finger tight. This will seat the Bal seal.
5. Install a sample tube on the SIP to ensure that the outer sleeve has been properly installed.
If the sleeve hits the bottom of the tube, loosen the retainer slightly and push the sleeve up as far as it will go. Tighten the retainer.

Changing the sample tube O-ring

Introduction

This topic describes how to replace the sample tube O-ring.

The sample tube O-ring, located within the retainer, forms a seal that allows the droplet containment vacuum to function properly.

When to replace the O-ring

Replace the O-ring when droplets form at the end of the sample injection tube while the vacuum is operating.

Caution



Caution: Biohazard! Cytometer hardware might be contaminated with biohazardous material. Wear suitable protective clothing, eyewear, and gloves whenever cleaning the cytometer or replacing parts.

Procedure

To change the O-ring:

1. Remove the outer sleeve from the sample injection tube by turning the retainer counterclockwise.
2. Slide the outer sleeve from the retainer.

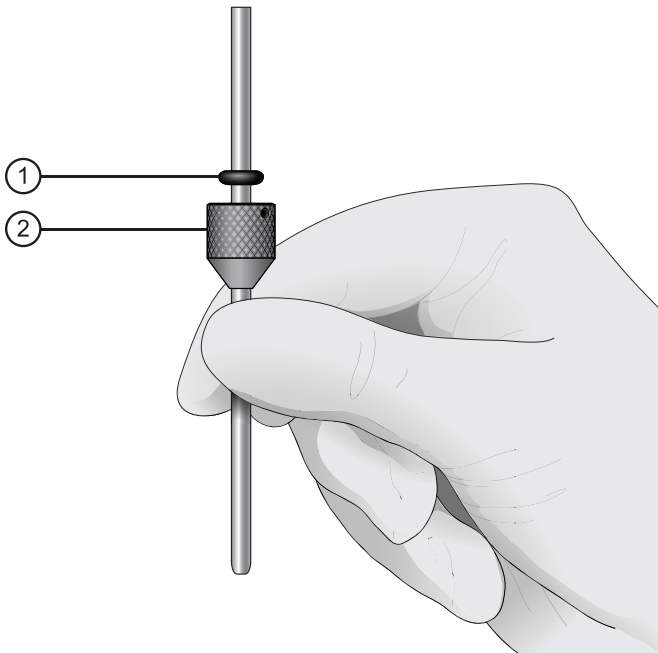

Item Number	Component
1	O-ring
2	Retainer

3. Invert the outer droplet sleeve and allow the O-ring to fall onto the benchtop.

If the O-ring does not fall out initially, hold the O-ring with your free hand and slide the outer sleeve to remove the O-ring.

4. Place the new O-ring into the retainer. Make sure the O-ring is seated properly in the bottom of the retainer.
5. Replace the outer sleeve in the retainer.
6. Re-install the retainer and the outer sleeve.
7. Install a sample tube on the SIP to ensure that the outer sleeve has been properly installed.

If the sleeve hits the bottom of the tube, loosen the retainer slightly and push the sleeve up as far as it will go. Tighten the retainer.

Cleaning or replacing the sheath gasket

Introduction

This topic describes how to clean or replace the gasket of the sheath tank lid.

When to change the sheath filter

We recommend cleaning the sheath gasket when needed.

Procedure

To clean or replace the gasket:

1. Put the cytometer in standby mode.
2. Depressurize the sheath container by pulling up on the vent valve.
3. Remove the lid from the sheath tank.
4. Remove the black gasket from the lid.
5. Rinse it with water to clean the gasket.
6. Place the clean gasket or the new gasket on the lid and make sure the gasket is seated properly on the lid.

This page intentionally left blank

5

Spectral Functions

This chapter covers the following topics:

- [Spectral function overview \(page 48\)](#)
- [Autofluorescence \(page 52\)](#)
- [Spectral unmixing software considerations \(page 53\)](#)
- [Setting up a new spectral experiment \(page 53\)](#)
- [Setting up the Spectral Unmixing algorithm \(page 56\)](#)
- [Recording and analyzing spectral data \(page 59\)](#)
- [Repeating a spectral experiment \(page 61\)](#)

Spectral function overview

Spectral flow cytometry represents an alternative measurement strategy to compensation flow cytometry. In both cases, surface markers or intracellular analytes on single cells are quantified by measuring antigen-specific fluorescent labels with varying spectral properties.

Compensation flow cytometry follows a paradigm of one detector per label in which the intensity of light emitted from the different labels is measured using label-specific photodetectors. The resulting data is subsequently transformed through a process called “compensation” to correct for the effects of spectral overlap between different fluorophores. Mirrors and filters that are broad enough to identify the target fluorescent label but also narrow enough to limit fluorescent spillover direct discrete portions of emitted light from each fluorescent label to the corresponding detector. This can lead to the omission of portions of spectral information that, when measured and transformed appropriately, could have aided in discriminating one fluorescent label from another.

In contrast, spectral cytometry uses a set of photodetectors spanning the visible spectrum—similar to a traditional spectrometer—to sample the full emission spectrum of all fluorescent labels present on the cell, and then uses a deconvolution process called spectral unmixing to determine the underlying label abundances. In spectral cytometry, sampling the full spectrum allows the cytometer to collect all light emitted from fluorescent labels and distinguish them from others in a multicolor experiment. This can provide advantages in flexibility of fluorescent label inputs without having to change filters, as well as the ability to multiplex more fluorescent labels in one multicolor sample.

In both cases, spillover spreading remains the primary limiting factor for panel performance and both spectral and compensation sampling methods entail many of the same requirements for experimental design and customer workflow. It is critical in both cases for single-stained reference controls to match the final sample as closely as possible. However, spectral cytometry can be more sensitive to discrepancies between the fluorochrome spectra in single-stained controls and the fully stained sample of interest.

The BD FACSymphony™ A5 SE is an RUO solution for a high-parameter spectral analyzer. Its spectral capabilities are enabled by the combination of optimized fixed configurations of lasers, standard filter set, and detectors. The software for the instrument, BD FACSDiva™ v9.3 or later, supports customer workflows that can be either spectral or traditional compensation experiments. This section describes the spectral functionality and workflows.

The BD FACSymphony™ A5 SE is a 5-laser, 48-fluorescent-channel instrument where each channel is assigned to a specific laser. The number of channels assigned to each laser is as follows:

- UV laser: 10 fluorochrome channels
- Violet laser: 14 fluorochrome channels
- Blue laser: 9 fluorochrome channels + side-scatter channel (SSC)
- Yellow-green laser: 9 fluorochrome channels
- Red laser: 6 fluorochrome channels

For each laser, each of its channels is routed to a different detector. As can be seen from the following figure, the only significant gaps in spectral response are near the laser emission wavelengths.

5 Lasers, 49 Channels

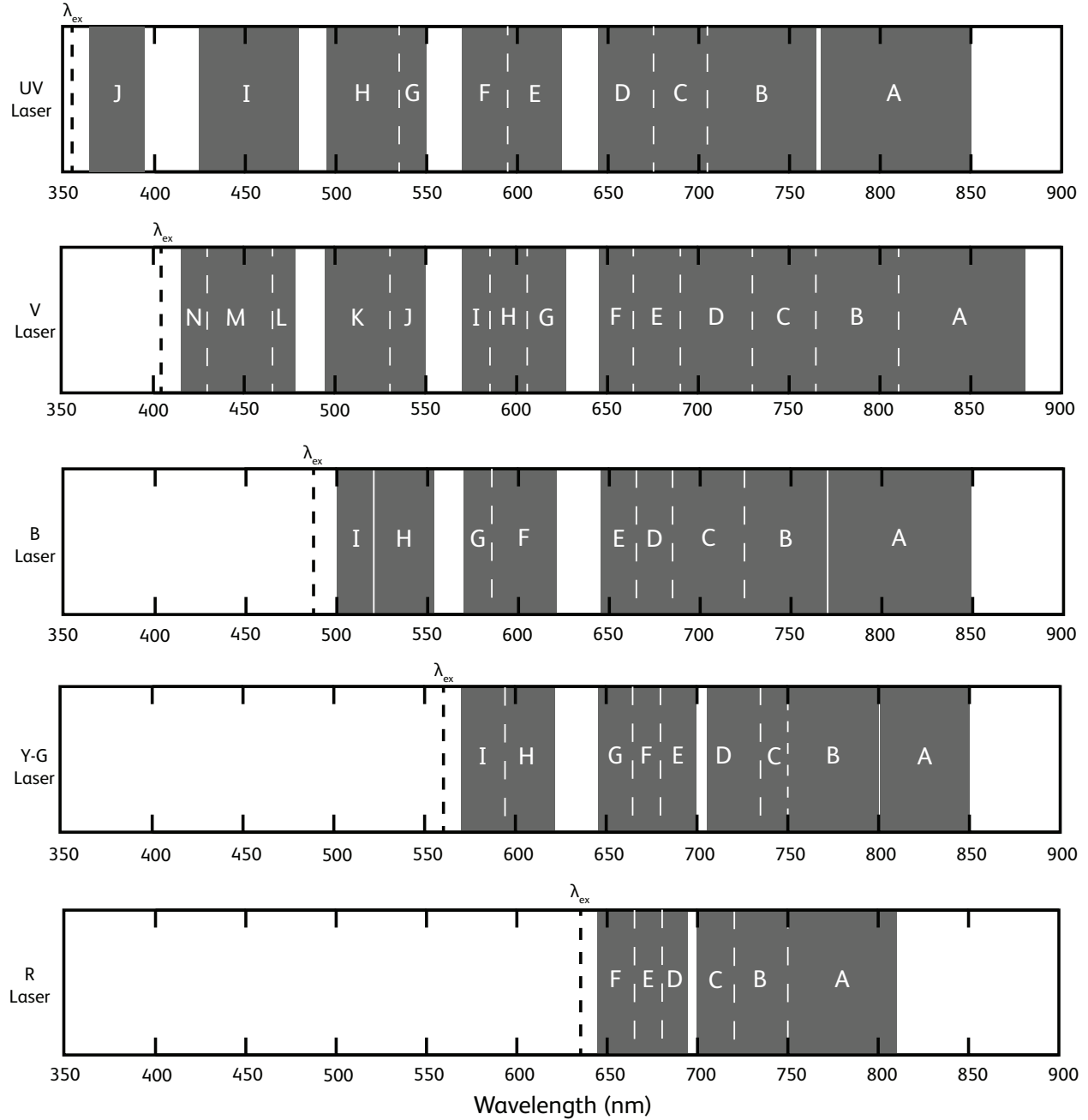

The BD FACSymphony™ A5 SE achieves the illustrated spectral responses using the following laser /detector/filter combinations:

Laser	Detector	Channel	Mirror	Filter	Parameter
Blue (488 nm)	A	10	770 LP	810/79 BP	B810
	B	9	724 LP	750/60 BP	B750
	C	8	685 LP	710/50 BP	B710
	D	7	665 LP	675/20 BP	B675
	E	6	645 LP	660/30 BP	B660
	F	5	585 LP	602/40 BP	B602
	G	4	570 LP	576/20 BP	B576
	H	3	520 LP	537/32 BP	B537
	I	2	500 LP	510/20 BP	B510
	J	1	–	488/10 BP	SSC
Red (637 nm)	A	16	750 LP	780/60 BP	R780
	B	15	720 LP	730/50 BP	R730
	C	14	699 LP	710/25 BP	R710
	D	13	680 LP	680/30 BP	R680
	E	12	665 LP	675/20 BP	R675
	F	11	645 LP	660/30 BP	R660
Violet (405 nm)	A	28	810 LP	845/70 BP	V845
	B	27	765 LP	785/50 BP	V785
	C	26	730 LP	750/40 BP	V750
	D	25	690 LP	710/40 BP	V710
	E	24	665 LP	680/30 BP	V680
	F	23	645 LP	660/30 BP	V660
	G	22	605 LP	615/25 BP	V615
	H	21	585 LP	595/30 BP	V595
	I	20	570 LP	576/20 BP	V576
	J	19	530 LP	540/20 BP	V540
	K	18	495 LP	510/40 BP	V510
	L	17	465 LP	470/15 BP	V470
	M	30	430 LP	450/40 BP	V450
	N	29	415 LP	427/25 BP	V427

Laser	Detector	Channel	Mirror	Filter	Parameter
UV (355 nm)	A	40	765 LP	809/32 BP	UV809
	B	39	704 LP	736/64 BP	UV736
	C	38	675 LP	695/40 BP	UV695
	D	37	645 LP	660/30 BP	UV660
	E	36	595 LP	610/30 BP	UV610
	F	35	570 LP	585/30 BP	UV585
	G	34	535 LP	540/20 BP	UV540
	H	33	495 LP	515/60 BP	UV515
	I	32	425 LP	446.5/67 BP	UV446
	J	31	365 LP	379/34 BP	UV379
Yellow-Green (561 nm)	A	49	800 LP	825.5/49 BP	YG825
	B	48	750 LP	780/60 BP	YG780
	C	47	735 LP	750/40 BP	YG750
	D	46	699 LP	730/50 BP	YG730
	E	45	680 LP	695/40 BP	YG695
	F	44	665 LP	670/20 BP	YG670
	G	43	645 LP	660/30 BP	YG660
	H	42	595 LP	602/40 BP	YG602
	I	41	570 LP	585/30 BP	YG585

The following table contains a list of common dyes and the primary or secondary detector parameters to use with them. When using multiple single-color fluorochrome controls, each control should be assigned to a detector not used by any of the other single-color controls. When possible, assign each control to its primary detector. If two controls that you are using share the same primary detector, assign one of them to a secondary detector instead.

Dye	Primary	Secondary	Dye	Primary	Secondary
Alexa Fluor 488	B537	–	BUV805	UV809	–
Alexa Fluor 647	R675	–	BV421	V427	–
Alexa Fluor 700	R730	R710	BV480	V470	–
APC	R675	R680	BV510	V510	–
APC-Cy7	R780	YG780	BV570	V576	–
APC-H7	R780	YG780	BV605	V595	–
APC-R700	R710	–	BV650	V660	–
BB515	B510	B537	BV711	V710	–
BB630	B602	–	BV750	V750	–
BB660	B660	–	BV786	V785	–
BB700	B710	B750	FITC	B510	B537
BB755	B750	–	PE	YG585	–
BB790	B810	–	PE-CF594	YG602	–
BUV395	UV379	–	PE-Cy5	YG660	–
BUV496	UV515	–	PE-Cy7	YG780	–
BUV563	UV585	–	PerCP	B675	–
BUV615	UV610	–	PerCP-Cy5.5	B710	B750
BUV661	UV660	–	R718	R730	R710
BUV737	UV736	–	V450	V450	–

Autofluorescence

Autofluorescence is the intrinsic fluorescent signal produced by a cell when stimulated by lasers. It is present to some extent on all particles, and varies from cell type to cell type (for example, monocytes have a different autofluorescence spectrum than lymphocytes). Spectral unmixing can be used to extract the autofluorescence spectrum of the cells of interest in your experiment and to separate this intrinsic fluorescent signal from the signal emitted by the fluorochromes in your experiment.

The autofluorescence control is the "single-stained" control for the autofluorescence in the experiment. In a spectral experiment, autofluorescence is unmixed as if it were another fluorochrome in your experiment. The autofluorescence control must use the same cell type as your fully stained sample. The other single-stained controls are not constrained in this way. For example, beads could be used for the other single-stained controls, but not for the autofluorescence control.

To add an autofluorescence control, see [Setting up a new spectral experiment \(page 53\)](#).

Spectral unmixing software considerations

When you perform spectral unmixing in BD FACSDiva™ software, you can also view compensated (non-spectral) data in that software.



Caution!

Do not delete any fluorescent parameters. Doing so will remove the ability of the BD FACSymphony™ A5 SE flow cytometer to perform spectral unmixing.

For each reagent in your experiment, you will need to select a “primary” detector, typically the detector that overlaps or is closest to that fluorochrome’s main emission peak on its primary exciting laser. These detectors will serve as the “conventional” detectors for each fluorochrome in compensation mode, and will also be used for gating to define positive populations in your single-stained controls. Labeling the parameter is necessary for spectral unmixing in BD FACSDiva™. See the tables in [Spectral function overview \(page 48\)](#) for information about the parameters and the primary parameters associated with some commonly used commercial dyes.

Setting up a new spectral experiment

The following procedure references buttons on the Workspace toolbar in BD FACSDiva™. These are:

- Browser
- Cytometer
- Inspector
- Worksheet
- Acquisition Dashboard

When you add elements or make selections in the Browser, the **Inspector** displays details, properties, and options that correspond to your selection.

1. Create a new experiment and rename it:
 - a. Click **Browser** in the Workspace toolbar.
 - b. Click the **New Folder** button in the Browser toolbar.
 - c. Click the folder and rename it.
 - d. With the renamed folder still selected, click the **New Experiment** button on the Browser toolbar.



- e. Click the new experiment entry in the Browser and rename it.
2. Create a new specimen by clicking the **New Specimen** button on the Browser toolbar and rename it.

- Verify that the base configuration, **FACSymphony A5 SE Default Configuration**, is selected as described in [Verifying the configuration and user preferences \(page 65\)](#).

Note: Spectral experiments must use the base configuration. Custom configurations may only be used in compensation workflows.

- Navigate to **Experiment > Experiment Layout** and assign parameter labels for each reagent to an individual primary detector. Typically, both the dye and the antibody names are added to the label, as shown in the following example. To add an autofluorescence control to your experiment, assign the label "AutoF" to parameter UV446. If that parameter is already assigned to another fluorochrome in your experiment, select any of parameters UV379–UV540 or V427–V540 for AutoF.

Name	Label	Label	Label	Label	Label	Label	Label	Label	Label	Label	Label
Experiment_001											
Specimen_001											
Tube_001	UV379	UV446 AutoF	UV515	UV540	UV585	UV610	UV660	UV695	UV736	UV809 BLV805 CD45RA	V427 BV421 CD28

Note: The "AutoF" label is case-sensitive. The autofluorescence control is only supported in spectral workflows, not compensation workflows.

- Adjust the flow cytometer settings as needed for your experiment, including and PMT voltage and area scaling.

Note: For spectral experiments, create a spectral plot to assist with adjusting PMT voltage settings. Using a spectral plot lets you ensure that the signal across all detectors is on-scale, not just the signal for the primary detector for each fluorochrome. For details about spectral plots, see the note at the end of this procedure.

- For details about adjusting PMT voltage settings for the unstained sample and single-color control tubes, see [Creating application settings \(page 72\)](#).
- For details about adjusting area scaling, see [Adjusting area scaling \(page 90\)](#).

- Set the Current Tube Pointer to the previously created sample tube with labeled parameters.
- Create any plots, gates, and statistics needed for data analysis. For details, refer to the *BD FACSDiva™ Software Reference Manual*.

Note: In addition to the dot and density plots, contour plots, and histogram plots for single-parameter data used in compensation cytometry, the BD FACSymphony™ A5 SE flow cytometer features the ability to create spectral plots, where the plot shows combined color-coded histograms of all raw detector values. The icon on the worksheet toolbar for creating a spectral plot is outlined in red in the following illustration:



The detector names displayed along the x-axis are formed by combining the first character of the laser color with the center value of the filter bandpass range for that detector.

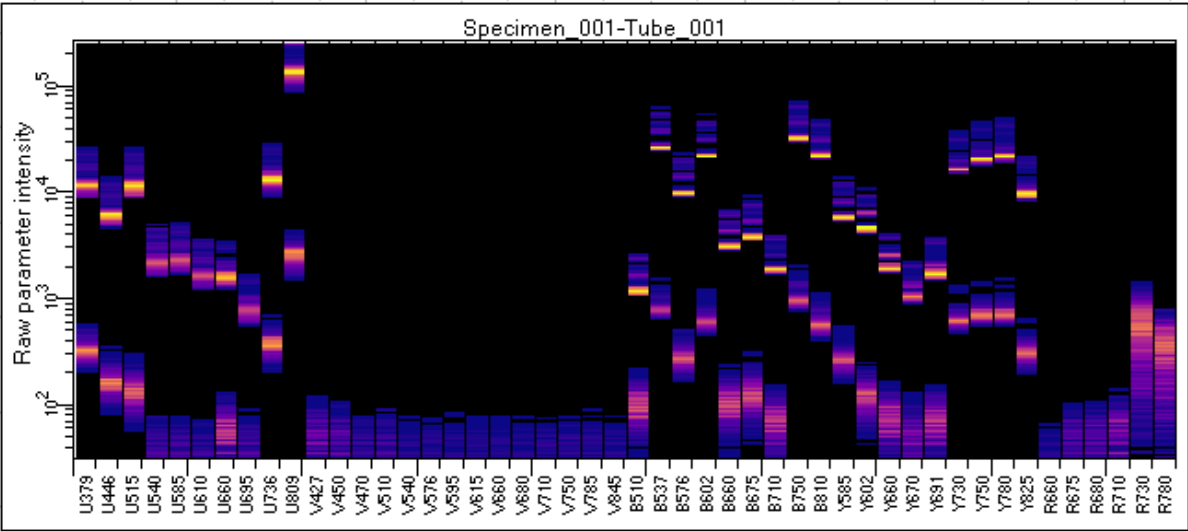

The plot supports the display of specific populations or combinations of populations, and displays live data during acquisition. Density color schemes or color by population can be modified in the inspector window when the plot is selected.

The spectral plot does not support zoom, biexponential scaling, or gate drawing.

Setting up the Spectral Unmixing algorithm

1. With the Current Tube Pointer to the previously created sample tube with labeled parameters, select **Experiment > Compensation Setup > Create Compensation Controls** from the main menu.

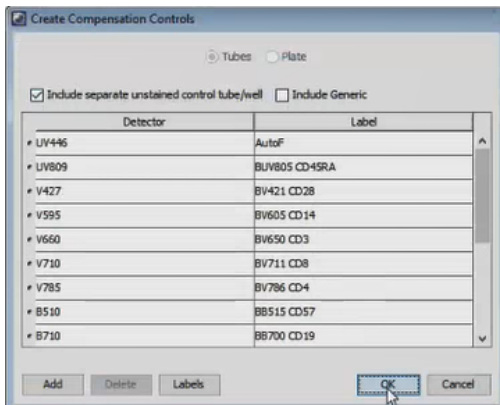

2. Leave the checkbox **Include Generic** in its default (deselected) state.
3. Click **OK** to create the controls. This adds the controls to the experiment Browser window, under **Compensation Controls**, and creates a tab for each control on the worksheet. If you assigned AutoF to a detector in the experiment layout, an AutoF control tube will display here too, as shown in the following example.

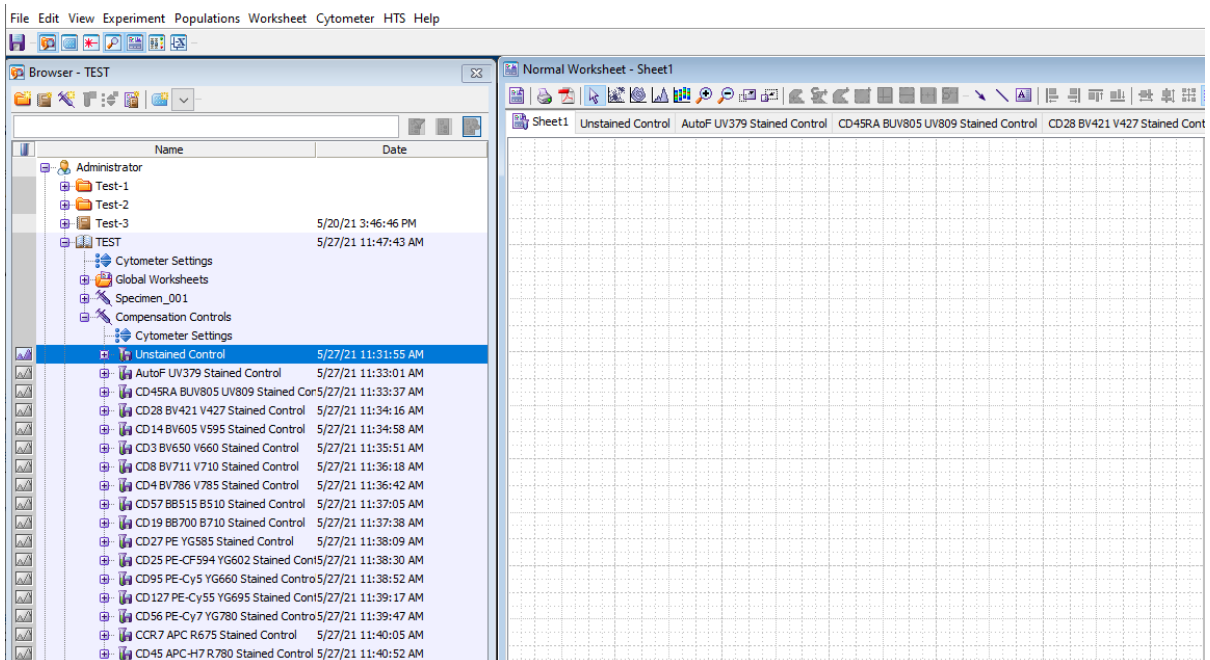

4. If you have a separate tube for your unstained control, record the unstained control as follows:
 - a. Select the **Unstained Control** tab on the worksheet.
 - b. In the experiment Browser, set the run pointer on **Unstained Control**.
 - c. On the Acquisition Dashboard, click **Acquire Data**.

- d. Move the P1 gate to cover the events of interest.
- e. (Optional) Right-click the gate and select **Apply to All Compensation Controls** from the context menu.
- f. In the Acquisition Dashboard, click **Record Data**.

The acquisition and recording automatically stops when the number of events in the **Events to Record** list box is reached (default value is 5000 events).

5. Record each of the single-color controls as follows:
 - a. Load the single-color control tube. If you are using an autofluorescence control in your experiment, record your autofluorescence tube using your unstained cell sample.
 - b. Select the tab for the single-color control on the worksheet.
 - c. In the experiment Browser, set the run pointer on the corresponding control.
 - d. On the Acquisition Dashboard, click **Acquire Data**.
 - e. If necessary, move the P1 gate on the left dot plot to include the events of interest.
 - f. In the Acquisition Dashboard, click **Record Data**.
 - g. When the recording completes, remove the control tube.
 - h. If necessary, adjust the position and width of the P2 gate to span the positive population on the histogram.

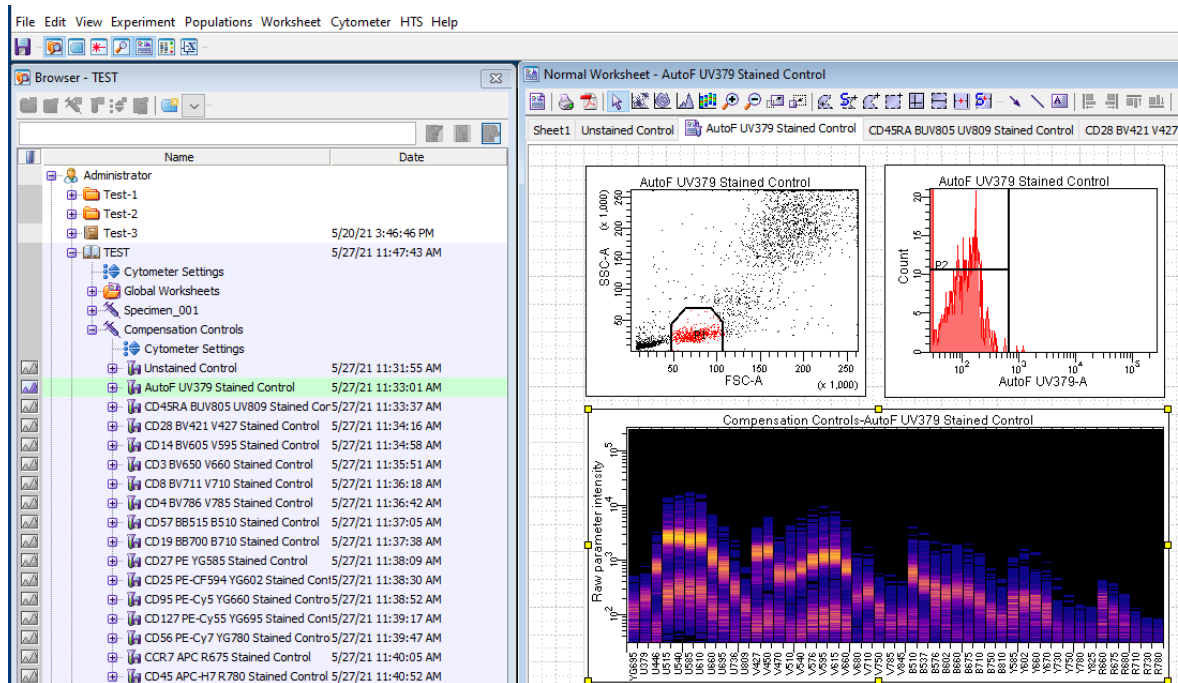

6. Select *Experiment > Compensation Setup > Calculate Spectral Unmixing*.

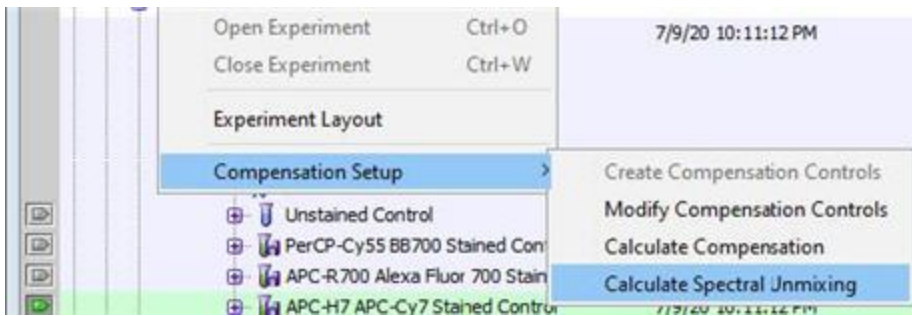

The screen displays the Single Stained Setup dialog.

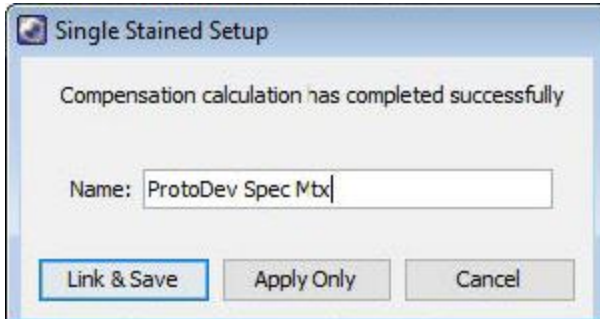

7. Enter a name for the setup and click **Link & Save**.

When the software calculates spectral unmixing, it also calculates compensation values (as if you had selected **Experiment > Compensation Setup > Calculate Compensation**). Compensation setup does not take autofluorescence into account. By default, when you select spectral unmixing, **Spectral** is selected in the dropdown menu on the **Compensation** panel of the Cytometer window as shown in the following example:

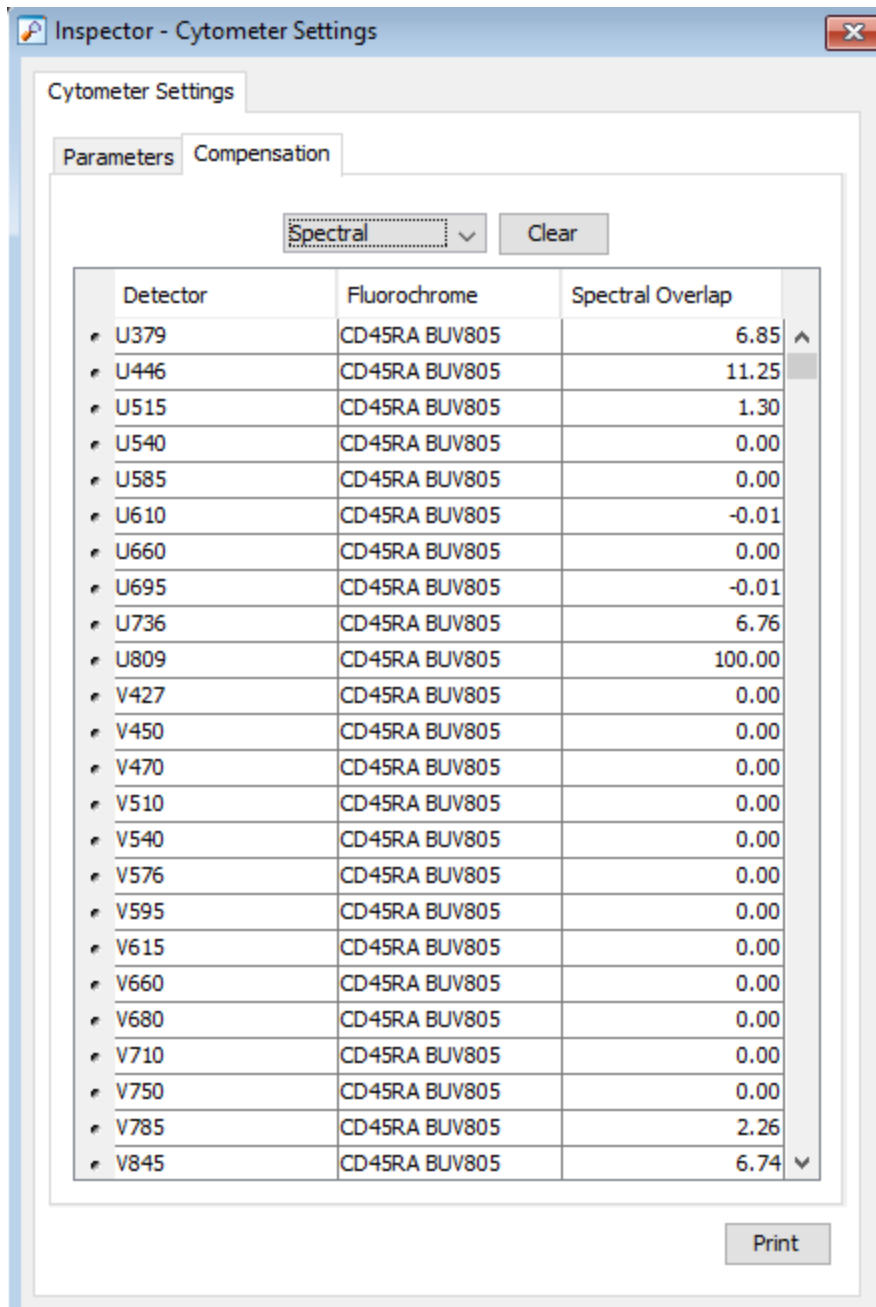

You can elect to switch between spectral unmixed and traditional compensation values, by toggling between **Spectral** and **Compensated** in the dropdown menu, to compare the plot data in each case.

Recording and analyzing spectral data

1. If needed, with the specimen tube selected, create more plots, gates, and statistics in addition to those created when initially setting up the experiment.
2. Record sample data using the initial tube.

- To acquire and record more tubes, click **Next Tube** and/or **Duplicate the Specimen**. Tubes must have the same parameter labels as was set up in the Spectral Unmixing algorithm by the **Create Compensation Controls** menu command.

When the software calculates spectral unmixing, it also calculates compensation values (as if you had selected **Experiment > Compensation Setup > Calculate Compensation**). Compensation setup does not take autofluorescence into account. By default, when you select spectral unmixing, the **Spectral** settings are selected in the dropdown menu on the **Compensation** panel of the Inspector window as shown in the following example:

Detector	Fluorochrome	Spectral Overlap
U379	CD45RA BUV805	6.85
U446	CD45RA BUV805	11.25
U515	CD45RA BUV805	1.30
U540	CD45RA BUV805	0.00
U585	CD45RA BUV805	0.00
U610	CD45RA BUV805	-0.01
U660	CD45RA BUV805	0.00
U695	CD45RA BUV805	-0.01
U736	CD45RA BUV805	6.76
U809	CD45RA BUV805	100.00
V427	CD45RA BUV805	0.00
V450	CD45RA BUV805	0.00
V470	CD45RA BUV805	0.00
V510	CD45RA BUV805	0.00
V540	CD45RA BUV805	0.00
V576	CD45RA BUV805	0.00
V595	CD45RA BUV805	0.00
V615	CD45RA BUV805	0.00
V660	CD45RA BUV805	0.00
V680	CD45RA BUV805	0.00
V710	CD45RA BUV805	0.00
V750	CD45RA BUV805	0.00
V785	CD45RA BUV805	2.26
V845	CD45RA BUV805	6.74

You can elect to switch between spectral unmixed and traditional compensation values, by toggling between **Spectral** and **Compensated** in the dropdown menu, to compare the plot data in each case.

- To export spectral BD FACSDiva™ FCS files, select the file or files to export, right-click and select **Export > FCS Files**.



Caution!

When exporting data to an FCS file, the exported data will reflect the setting applied in the dropdown control on the Compensation panel. Thus, if **Compensated** is selected in the dropdown menu, traditional compensation data will be exported, even if spectral unmixing was selected during compensation setup. To export spectral unmixed data, make sure that **Spectral** is selected in the Compensation panel.

- To export an experiment from the browser with all data included, click the Browser button in the Workspace toolbar to open the browser. Right-click the experiment in the browser and select **Export > Experiment**.
- If you want to repeat this experiment later, create an experiment template. For instructions about how to do this, refer to the *BD FACSDiva™ Software Reference Manual*.
- Delete experiments in the Browser panel as required.

Repeating a spectral experiment

To repeat an experiment, you need to create a new experiment using an experiment template and set its properties so they are the same as the experiment you want to repeat. For instructions about how to create an experiment template, refer to the *BD FACSDiva™ Software Reference Manual*.

- In the Browser, select a location to create the new experiment. If desired, create a new folder (from the menu bar, select **Experiment > New Folder**) and rename it.
- From the menu bar, select **Experiment > New Experiment**.

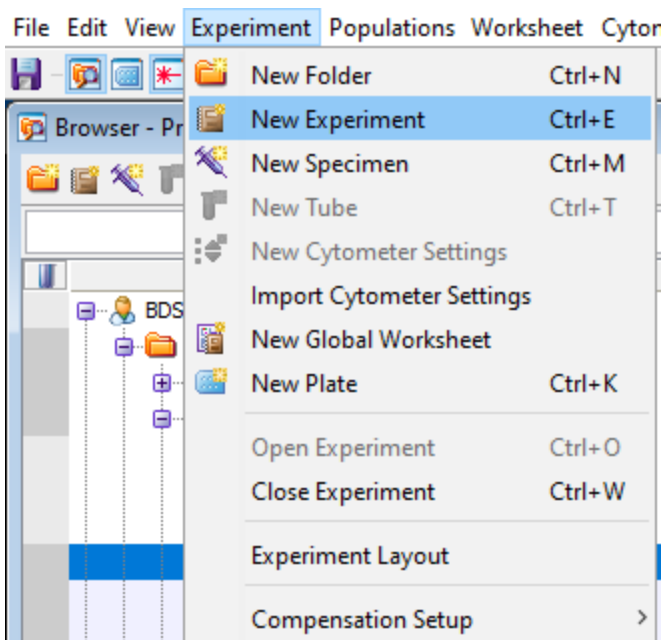

The Experiment Templates dialog is displayed.

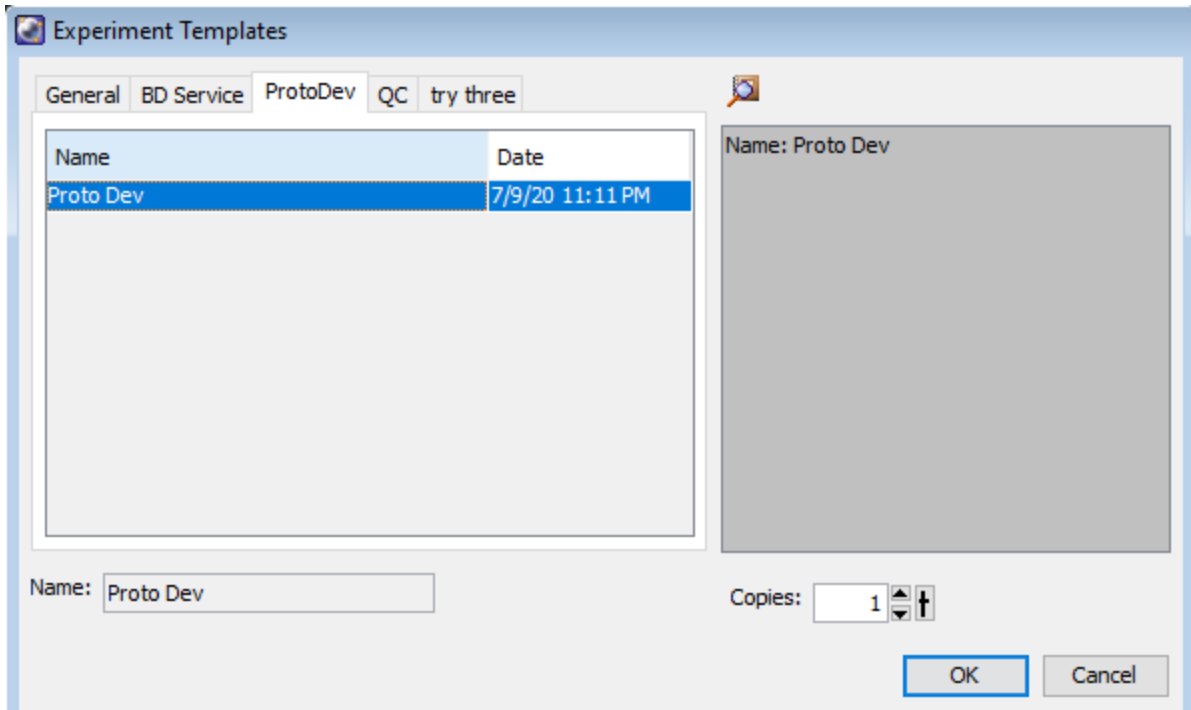

3. In the tab containing the experiment template that you want to load, select the template and click **OK**.
4. Confirm the parameters and labels are correct for the assay that you want to repeat.
5. Set up the spectral unmixing algorithm as described in [Setting up the Spectral Unmixing algorithm \(page 56\)](#).
6. Record and analyze spectral data as described in [Recording and analyzing spectral data \(page 59\)](#).

6

Optimizing cytometer settings

This chapter covers the following topics:

- [Cytometer settings workflow \(page 64\)](#)
- [Verifying the configuration and user preferences \(page 65\)](#)
- [Running a performance check \(page 67\)](#)
- [Setting up a compensation experiment \(page 69\)](#)
- [Creating application settings \(page 72\)](#)
- [Recording compensation controls \(page 73\)](#)
- [Calculating compensation \(page 76\)](#)

Cytometer settings workflow

Introduction

This topic describes how to optimize cytometer settings. The optimization is performed using the BD® Cytometer Setup Software, Application Settings, and Compensation Setup features of BD FACSDiva™ software.

When to optimize settings

Before you record data for a sample, optimize the cytometer settings for the sample type and fluorochromes used.

Manual compensation

Compensation setup automatically calculates compensation settings. If you choose to perform compensation manually, not all of the following instructions apply. For detailed instructions, see the *BD FACSDiva™ Software Reference Manual*.

First-time users

If you are performing the procedures in this workflow for the first time, you should be familiar with BD FACSDiva™ software concepts: workspace components, cytometer and acquisition controls, and tools for data analysis.

For additional details, see the *BD FACSDiva™ Software Reference Manual*.

Before you begin

Start the cytometer and perform the setup and QC procedures. See [Cytometer setup \(page 23\)](#).

Workflow for optimizing settings

Cytometer optimization consists of the following steps.

Step	Description
1	Verifying the configuration and user preferences (page 65)
2	Running a performance check (page 67)
3	Setting up a compensation experiment (page 69)
4	Creating application settings (page 72)
5	Recording compensation controls (page 73)
6	Calculating compensation (page 76)

Note: Application settings are optional and do not have to be saved for the experiments. However, they are useful for optimizing cytometer settings.

About the examples

The examples in this chapter use a 4-color bead sample with the following fluorochromes:

- FITC
- PE
- PerCP-Cy5.5
- APC

If you follow this workflow with a different bead sample (or another sample type), your software views, data plots, and statistics might differ from the example. Additionally, you might need to modify some of the instructions in the procedure.

The information shown in italics is for example only. You can substitute your own names for folders and experiments.

Verifying the configuration and user preferences

Introduction

This topic describes how to verify the cytometer configuration and user preferences before you create an experiment.



Caution! To obtain accurate data results, the current cytometer configuration must reflect your flow cytometer optics.

Procedure

To verify the configuration and preferences before you create an experiment:

1. Select **Cytometer > View Configurations** and verify the current configuration.

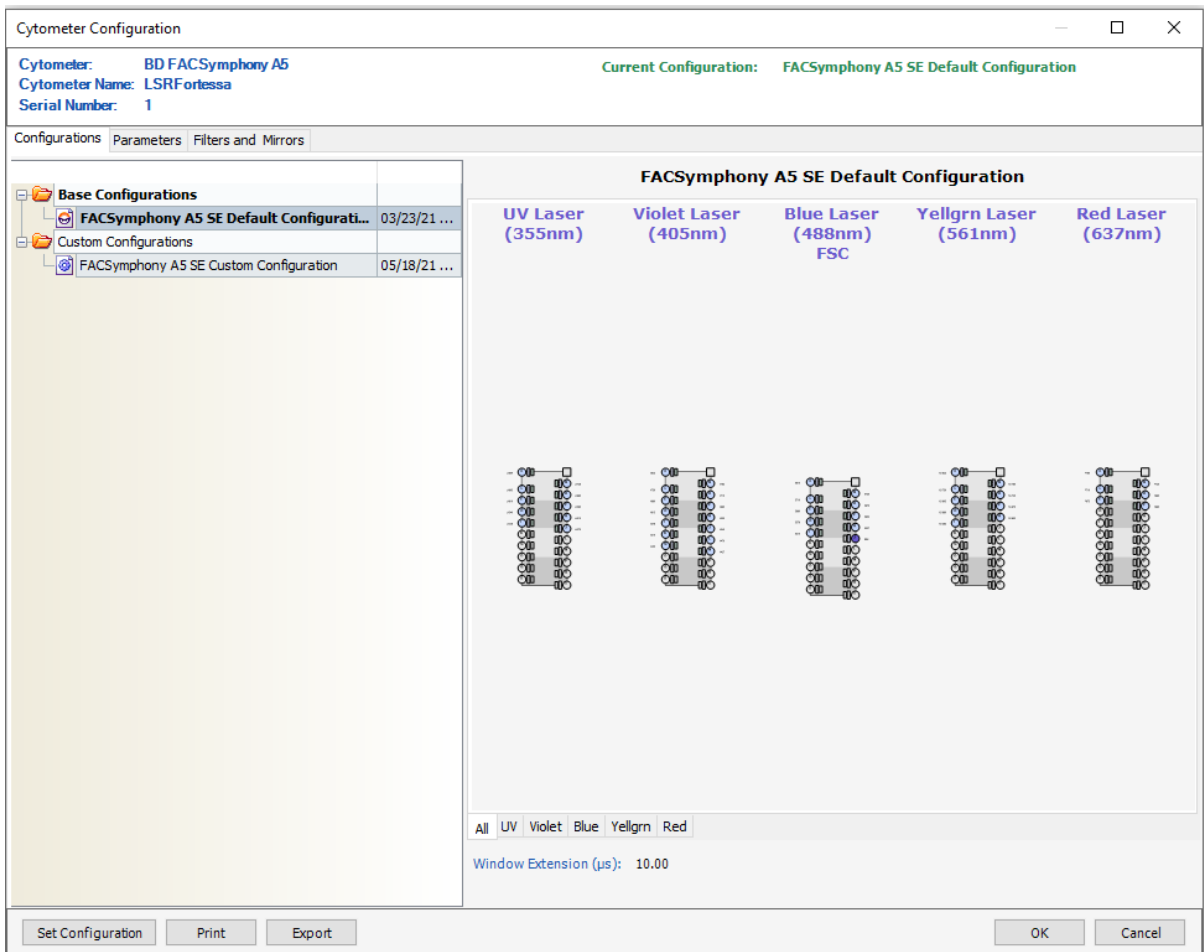

Your cytometer might include only the base configuration when your cytometer is installed. This configuration must always be used for spectral cytometry workflows. For compensation cytometry workflows, you can create custom configurations later as needed.

2. If you need to select a configuration other than the current configuration:
 - a. In the **Configurations** tab, select a configuration.
 - b. Click **Set Configuration**.
 - c. Click **OK**.
 - d. Verify that the configuration you just set matches your flow cytometer optics.
3. Click **OK** to close the **Cytometer Configuration** window.
4. Select **File > Exit** to close CS&T.
5. If the CST Mismatch dialog opens, click **Use CST Settings**.
6. Select **Edit > User Preferences**.
7. Click the **General** tab and select the **Load data after recording** checkbox.

See the *BD FACSDiva™ Software Reference Manual* for more information about cytometer configurations and user preferences.

Next step

[Running a performance check \(page 67\)](#)

More information

- [Setting up a compensation experiment \(page 69\)](#)

Running a performance check

Introduction

This topic describes how to run a performance check as part of quality control.

Overview

The CS&T application is designed to monitor performance on a daily basis and to optimize laser delay.

Running a performance check on a regular basis provides a standard for monitoring changes in performance due to degradation of laser power, aging of PMTs, and other potential cytometer service issues. Performance results are also affected by fluidics performance. We strongly recommend following the fluidics maintenance procedures as described in [Cleaning the fluidics \(page 37\)](#).

Considerations

Some BP filters might not be normalized to CS&T settings. In this case, CS&T will generate Qr and Br numbers that are not comparable from instrument to instrument. They are however, still trackable on one cytometer. Part of the process for optimizing cytometer settings includes verifying PMT voltages set by CS&T for all parameters.

Before you begin

Define the performance baseline for any configuration before running a performance check. See [Custom configurations and baselines \(page 34\)](#).

Procedure

To run a performance check:

1. Select **Cytometer > CST**.
2. Verify that the bead lot information under **Setup Beads** matches the Cytometer Setup and Tracking bead lot.

Setup Beads	
Lot ID:	00000 (RUO) <input type="button" value="v"/>
Product:	CST Setup Beads
Part #:	910858
Expiration Date:	01-22-2018

3. Verify that the cytometer configuration is correct for your experiment.

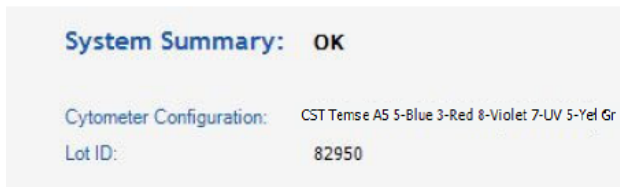

If the cytometer is not set to the correct configuration:

- a. Click **Select Configuration** in the **Setup Control** window.
 - b. Select the correct configuration from the list.
 - c. Click **Set Configuration** and then click **OK**.
4. Verify that the current configuration has a valid baseline defined.
 If not, see the *BD Cytometer Setup and Tracking Application Guide* for more information on defining a baseline.
5. [Prepare the CS&T beads according to the technical data sheet provided with the beads or available on the BD Biosciences website \(bdbiosciences.com\).](http://bdbiosciences.com)
6. Install the bead tube onto the SIP.
7. In the **Setup Control** window, select **Check Performance** from the **Characterize** menu.

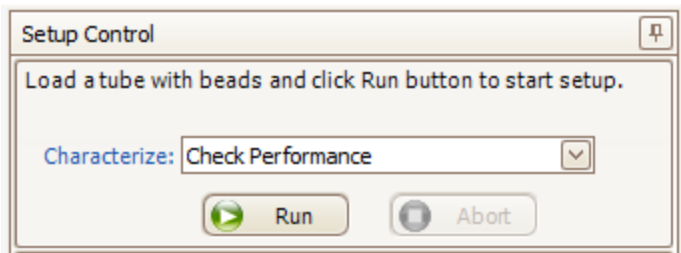

8. Click **Run**.
9. On the fluidics control panel, ensure that FINE Adj is set to 250, then press the RUN and LOW buttons.
 Plots appear under the Setup tab and the performance check is run. The performance check takes approximately 5 minutes to complete.
10. Once the performance check is complete, click **View Report**.
11. Verify that the cytometer performance passed.
 In the Setup tab, the cytometer performance results should have a green checkbox displayed and the word *Passed* next to it.

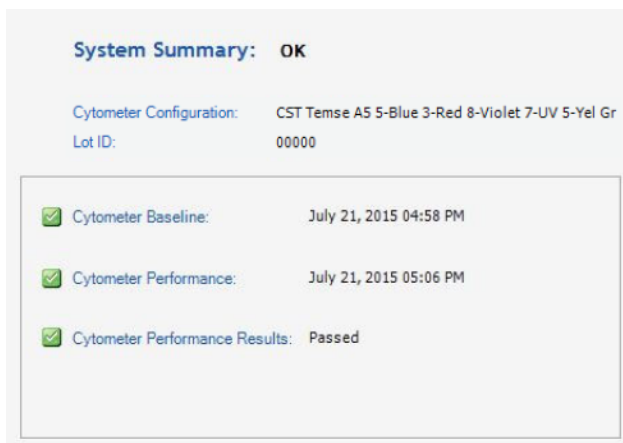

If any parameters did not pass, see the *BD Cytometer Setup and Tracking Application Guide* for troubleshooting information.

12. Select **File > Exit** to close the CS&T window and return to the BD FACSDiva™ interface.

The CST Mismatch dialog opens.

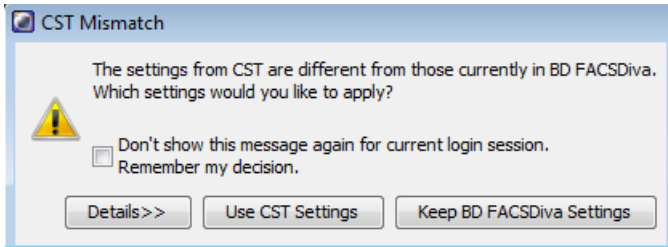

Click the **Details** button to verify which cytometer settings will be updated.

13. Click **Use CST Settings**.

By selecting Use CST Settings, the laser delay, area scaling, and other cytometer settings will be updated to the latest settings from the performance check.

Setting up a compensation experiment

Introduction

This topic describes how to create an experiment in a new folder, specify the parameters of the experiment, and add compensation tubes.

Creating an experiment

To create an experiment:

1. Click the buttons on the **Workspace** toolbar to display the following windows as needed:
 - Browser
 - Cytometer
 - Inspector
 - Worksheet
 - Acquisition Dashboard

When you add elements or make selections in the Browser, the Inspector displays details, properties, and options that correspond to your selection.

2. Click the **New Folder** button on the **Browser** toolbar to add a new folder.
3. Click the folder and rename it *MyFolder*.
4. Click *MyFolder*, then click the **New Experiment** button on the **Browser** toolbar.



- a. Click the new experiment in the **Browser** and rename it *MyExperiment*.
5. Select *MyExperiment* in the **Browser**.
The Inspector displays details for the experiment.

Specifying parameters

To specify the parameters for the new experiment:

1. Select **Cytometer Settings** for the experiment in the **Browser**.

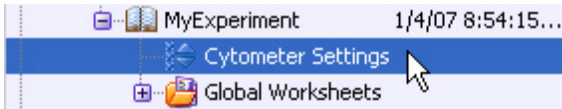

Cytometer settings appear in the **Inspector**.

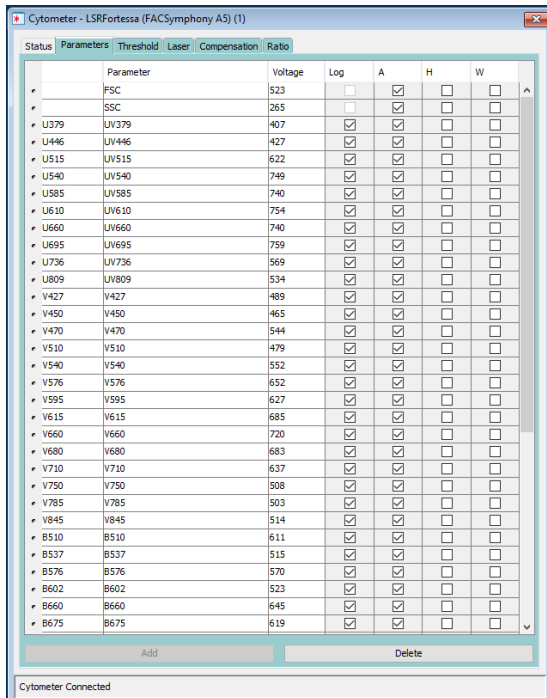

2. Make sure the parameters you need appear on the **Parameters** tab in the **Inspector**.
 - a. Click a **Parameter** name to display the available fluorochromes in the **Parameters** list.
 - b. Select the specific parameter from the menu. Your selection appears as the selected parameter.

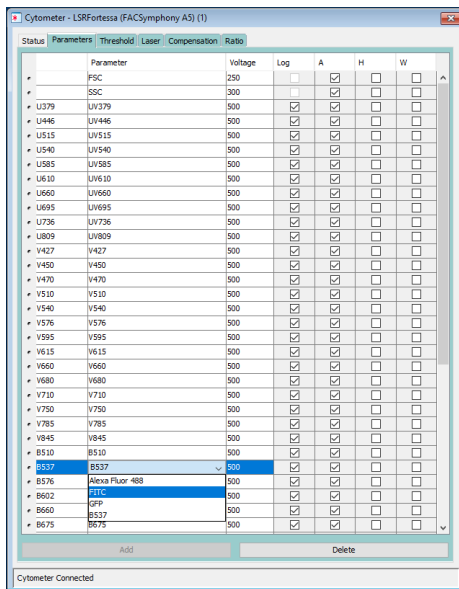

c. For this example, select **FITC** from the menu.

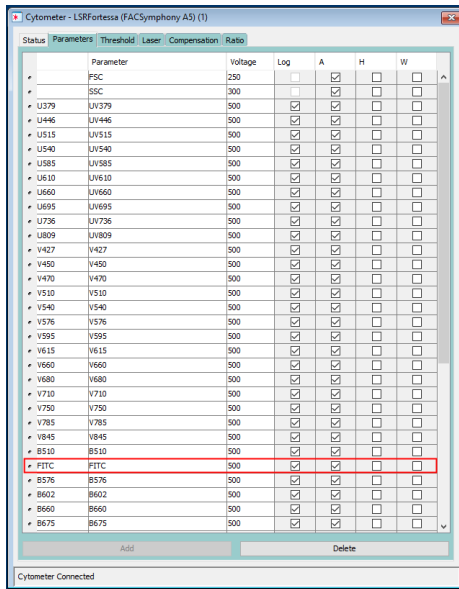

3. Delete any unnecessary parameters.

Note: Unnecessary parameters may only be deleted when running in compensation mode.

a. Click the selection button (to the left of the parameter name) to select the parameter.

b. Click **Delete**.

The parameter is deleted.

Creating application settings

Introduction

This topic describes how to create application settings.

About application settings

Application settings are associated with a cytometer configuration and include the parameters for the application, area scaling values, PMT voltages, and threshold values, but not compensation. Each time a performance check is run for a configuration, the application settings associated with that configuration are updated to the latest run.

Using application settings provides a consistent and reproducible way to reuse cytometer settings for commonly used applications.

You can include area scaling adjustment in your application settings. See [Adjusting area scaling \(page 90\)](#) for more information.

Before you begin

Perform the cytometer setup procedure and run a performance check for the configuration that will be used for the application.

Procedure

To create application settings:

1. In the open experiment, right-click **Cytometer Settings** in the **Browser**, then select **Application Settings > Create Worksheet**.

A second global worksheet is added with the plots created according to the selections in the Parameters tab.

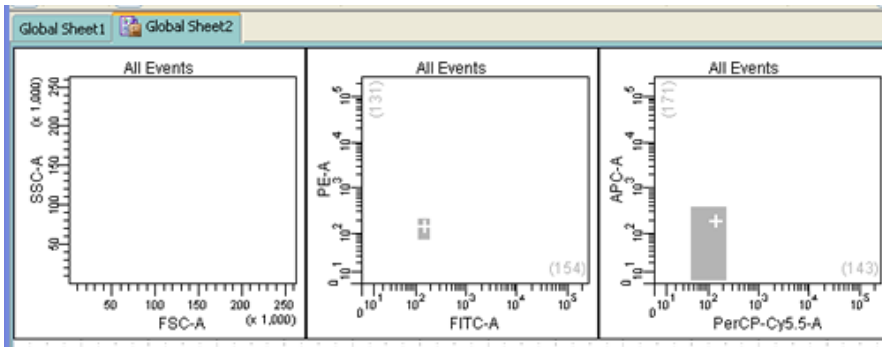

Use the gray boxes and crosshairs to guide your optimization.

2. Create a new specimen and tube.
3. Load the unstained control tube onto the cytometer.
4. In the **Cytometer** window, optimize the PMT voltages for the application.
 - Optimize the FSC and SSC voltages to place the population of interest on scale.
 - Optimize the FSC threshold value to eliminate debris without interfering with the population of interest.

- If needed, increase the fluorescence PMT voltages to place the negative population within the gray boxes. Align the center of the negative population with the crosshair visible in the gray box.

Note: Do not decrease the fluorescence PMT voltages. Doing so can make it difficult to resolve dim populations from the negative population.

5. Unload the unstained control tube from the cytometer.
6. Load the multicolor sample onto the cytometer or load a single-color control tube.
7. Verify that the positive populations are on scale.
If a positive population is off scale, lower the PMT voltage for that parameter until the positive population can be seen entirely on scale.
8. Unload the multicolor sample or single-color control tube.
9. If working with single-color control tubes, repeat steps 6–8 for every control tube to verify each fluorochrome signal separately.
10. Place a tube containing DI water on the SIP and put the cytometer on standby.
11. Save the application settings by right-clicking **Cytometer settings** in the **Browser**, then selecting **Cytometer Settings > Save**.
12. In the **Save Cytometer Settings** dialog, enter a descriptive name for the settings.

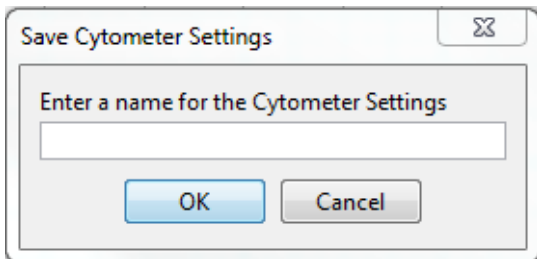

13. Click **OK**.
The application settings are saved to the catalog.

Next step

[Recording compensation controls \(page 73\)](#)

Recording compensation controls

Introduction

This topic describes how to create and record compensation controls using the Compensation Setup feature of BD FACSDiva™ software and an experiment with optimized settings.

Creating compensation tubes

To create compensation control tubes:

1. Select **Experiment > Compensation Setup > Create Compensation Controls**.
The Create Compensation Controls dialog opens.

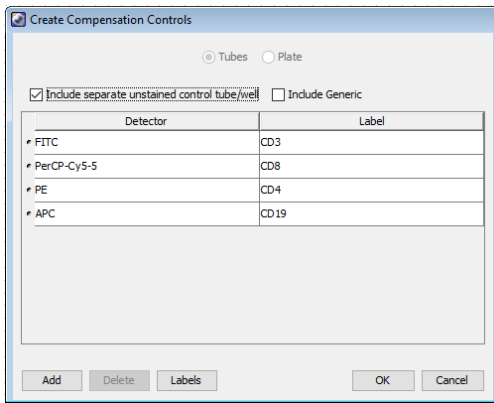

2. Set or clear the **Include separate unstained control tube/well** and/or **Include Generic** checkboxes as needed. Select **Include Generic** when running generic controls (not label-specific compensation). Select **Include separate unstained control tube** when preparing an unstained control in a separate tube (as opposed to being in the same tube as the single-stained control).
3. Click **OK**.

Compensation control tubes are added to the experiment. Worksheets containing appropriate plots and gates are added for each compensation tube.

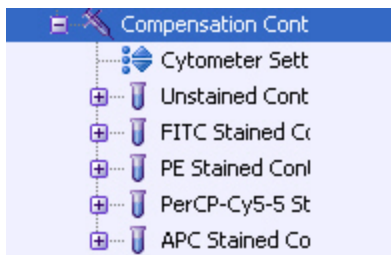

Recording compensation settings

To record compensation settings:

1. Press RUN and HIGH on the cytometer fluid control panel.
2. Install the unstained control tube onto the SIP.
3. Expand the **Compensation Controls** specimen in the **Browser**.
4. Set the current tube pointer to the unstained control tube (it becomes green), then click **Acquire Data** in the **Acquisition Dashboard**.
5. Verify that the population of interest is displayed appropriately on the FSC vs SSC plot and adjust voltages if necessary.

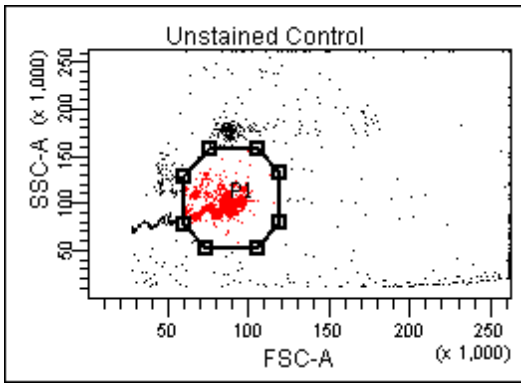

6. Adjust the P1 gate to surround only the singlets.
7. Right-click the P1 gate and select **Apply to All Compensation Controls**.
The P1 gate on each stained control worksheet is updated with your changes.
8. Click **Record Data**.
9. When recording is finished, remove the unstained control tube from the cytometer.
10. Click **Next Tube**.



Caution! Do not change the PMT voltages after the first compensation control has been recorded. In order to calculate compensation, all controls must be recorded with the same PMT voltage settings. If you need to adjust the PMT voltage for a subsequent compensation control, you must record all compensation controls again.

11. Install the next tube onto the cytometer and repeat steps 8 through 10 until data for all stained control tubes has been recorded.
12. Double-click the first stained control tube to display the corresponding worksheet.
13. Verify that the snap-to-interval gate encompasses the positive population.

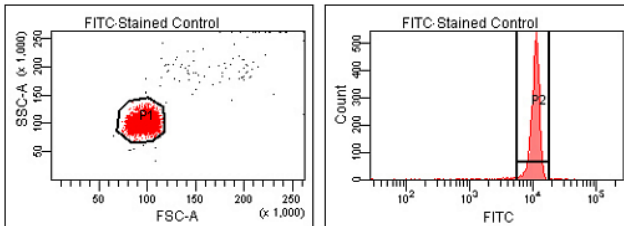

14. Repeat steps 12 and 13 for the remaining compensation tubes.

Next step

After you have recorded data for each single-stained control, calculate compensation as described in [Calculating compensation \(page 76\)](#).

Calculating compensation

Introduction

This topic describes how to calculate compensation.

Before you begin

Before you can calculate compensation, you need to record the data for each single-stained control.

Procedure

To calculate compensation:

1. Select **Experiment > Compensation Setup > Calculate Compensation**.

Note: If the calculation is successful, a dialog prompts you to enter a name for the compensation setup. The default name is year/month/day/time.

2. Enter a setup name and click **Link & Save**.

The compensation is linked to the cytometer settings and saved to the catalog.

To help track compensation setups, include the experiment name, date, or both in the setup name.

The compensation setup is linked to the *MyExperiment* cytometer settings, and subsequent acquisitions in *MyExperiment* are performed with the new compensation settings.

We recommend that you always visually and statistically inspect automatically calculated spectral overlap values. The means of the positive controls should be aligned with the means of the negative controls.

More information

- [Recording compensation controls \(page 73\)](#)

7

Recording and analyzing data

This chapter covers the following topics:

- [Data recording and analysis workflow \(page 78\)](#)
- [Preparing the workspace \(page 78\)](#)
- [Recording data \(page 79\)](#)
- [Analyzing data \(page 81\)](#)
- [Reusing an analysis \(page 84\)](#)

Data recording and analysis workflow

Introduction

This topic outlines the basic acquisition and analysis tasks using BD FACSDiva™ software.

About the examples

The examples in this chapter are from two 4-color bead samples with the following fluorochromes:

- FITC
- PE
- PerCP-Cy5.5
- APC

If you use a different sample type or if you have skipped the optimization steps in [Optimizing cytometer settings \(page 63\)](#), your software window content, names of folders and experiments, and your data plots and statistics might differ from those shown here. You might also need to modify some of the instructions in the procedure.

For additional details on completing some of the following steps, see the *BD FACSDiva™ Software Reference Manual*.

This procedure builds on the results obtained in [Optimizing cytometer settings \(page 63\)](#).

Workflow for recording and analyzing data

Recording and analyzing data consists of the following steps.

Step	Description
1	Preparing the workspace (page 78)
2	Recording data (page 79)
3	Analyzing data (page 81)
4	Reusing an analysis (page 84)

Preparing the workspace

Introduction

This topic describes how to prepare the workspace and apply application settings to your experiment before recording data.

Procedure

To prepare the workspace:

1. Using the Browser toolbar, create a new specimen in *MyExperiment* and rename it *FourColorBeads*.
2. Create two tubes for the *FourColorBeads* specimen. Rename the tubes *Beads_001* and *Beads_002*.

3. Expand the **Global Worksheets** folder in *MyExperiment* to access the default global worksheet, and rename the worksheet *MyData*.
4. On the *MyData* worksheet, create the following plots for previewing the data:
 - FSC vs SSC
 - FITC vs PE
 - FITC vs PerCP-Cy5.5
 - FITC vs APC

Applying saved application settings to a new experiment

When applications settings are applied to an experiment, the cytometer settings are updated with the parameters included in the application settings, optimized PMT voltages, threshold settings, area scaling factors, and window extension values.

To apply saved application settings to your experiment:

1. Right-click the experiment-level Cytometer Settings and select **Application Settings > Apply**.
2. In the **Application Settings** catalog, select the application settings file you saved previously and click **Apply**.
If the parameters are not the same, a mismatch dialog opens.
 - Click **Overwrite** to update all settings.
 - Click **Apply** to change only the common parameters.

For more information, see the *BD FACSDiva™ Software Reference Manual*.

The cytometer settings are renamed application settings and the cytometer settings icon in the Browser changes.

More information

- [Creating application settings \(page 72\)](#)
- [Recording data \(page 79\)](#)

Recording data

Introduction

This topic provides an example of how to preview and record data for multiple samples.

Before you begin

Prepare the sample tubes.

Note: If you need to run samples at an event rate greater than 10,000 events/second, consider changing your Window extension. See the *BD FACSDiva™ Software Reference Manual* for more information.

Recording data

To record data:

1. Press RUN and HIGH on the cytometer fluid control panel.
2. Install the first sample tube onto the SIP.
3. Set the current tube pointer to *Beads_001*.

4. Click **Acquire Data** in the Acquisition Dashboard to begin acquisition.
5. While data is being acquired:
 - a. Draw a gate around the singlets on the FSC vs SSC plot.
 - b. Rename the P1 gate to *Singlets*.
 - c. Use the **Inspector** to set the other plots to show only the singlet population by selecting the Singlets checkbox.

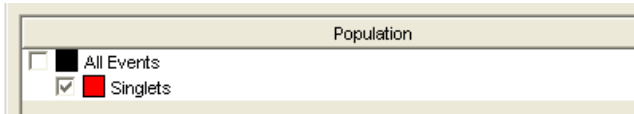

6. Click **Record Data**.
7. When event recording has completed, remove the first tube from the cytometer.

The *MyData* worksheet plots should look like the following.

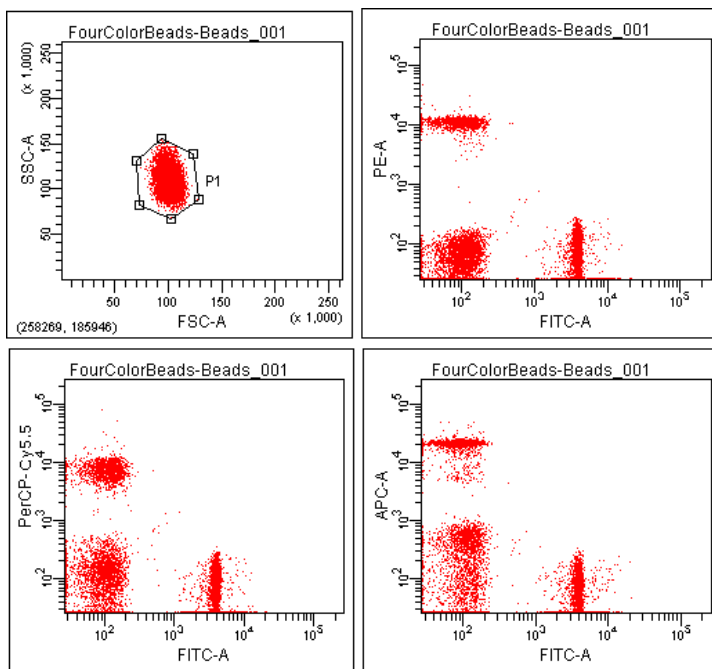

8. Install the second sample tube onto the SIP.
9. Set the current tube pointer to *Beads_002*.
10. Click **Acquire Data** to begin acquisition.
11. Before recording, preview the data on the *MyData* worksheet to verify that all expected populations are visible and the data is similar to the previous sample.
12. Click **Record Data**.
13. When event recording has completed, remove the second tube from the cytometer.
14. If you are recording more than two tubes, repeat steps 8 through 13 for the remaining tubes.
15. Print the experiment-level cytometer settings by right-clicking the **Cytometer Settings** icon in the **Browser** and selecting **Print**.
16. Install a tube of DI water onto the SIP.
17. Place the cytometer in standby mode.

More information

- [Analyzing data \(page 81\)](#)

Analyzing data

Introduction

This topic describes how to analyze recorded tubes by creating plots, gates, a population hierarchy, and statistics views on a new global worksheet.

Analyzing data

To analyze data:

1. Use the **Browser** toolbar to create a new global worksheet. Rename it *MyDataAnalysis*.
2. Create the following plots on the *MyDataAnalysis* worksheet:
 - FSC vs SSC
 - FITC vs PE
 - FITC vs PerCP-Cy5.5
 - FITC vs APC
3. Create a population hierarchy and a statistics view, and set them below the plots on the worksheet.
 - Right-click any plot and select **Show Population Hierarchy**.
 - Right-click any plot and select **Create Statistics View**.
4. Set the current tube pointer to *Beads_001*.
5. Draw a gate around the singlets on the FSC vs SSC plot.
6. Use the population hierarchy to rename the population *Singlets*.
7. Select all plots except the FSC vs SSC plot, and use the **Plot** tab in the **Inspector** to show only the singlet population.

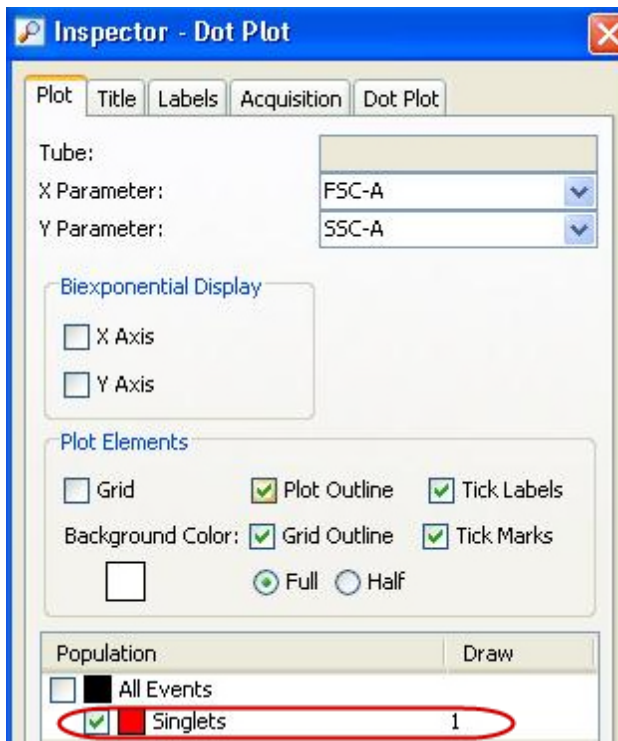

8. Select all plots, and click the **Title** tab in the **Inspector**.
9. Select the **Tube** and **Populations** checkboxes to display their names in plot titles.

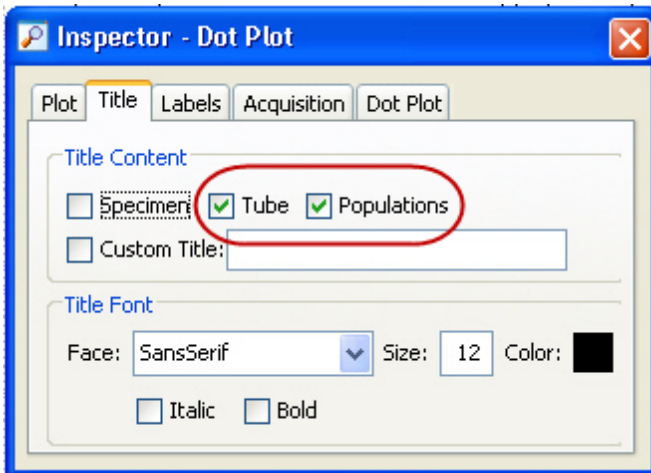

10. On all fluorescence plots:
 - Make all plots biexponential. Select all fluorescence plots and select the **X Axis** and **Y Axis** checkboxes in the **Plot** tab of the **Inspector**.

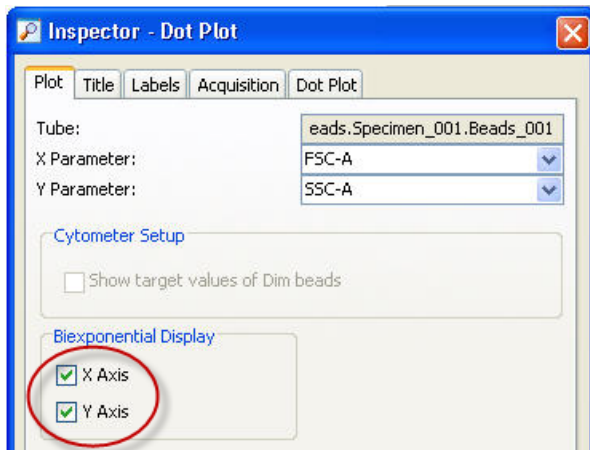

- In the FITC vs PE plot, draw a gate around the FITC-positive population. Name the population *FITC positive* in the population hierarchy.
 - In the FITC vs PE plot, draw a gate around the PE-positive population. Name the population *PE positive* in the population hierarchy.
 - In the FITC vs PerCP-Cy5.5 plot, draw a gate around the PerCP-Cy5.5-positive population. Name the population *PerCP-Cy5.5 positive* in the population hierarchy.
 - In the FITC vs APC plot, draw a gate around the APC-positive population. Name the population *APC positive* in the population hierarchy.
11. Format the statistics view.
- a. Right-click the statistics view and select **Edit Statistics View**.
 - b. Click the **Header** tab and select the **Specimen Name** and **Tube Name** checkboxes.
 - c. Click the **Populations** tab and select all populations except **All Events**. Clear the **%Parent**, **%Total**, and **#Events** checkboxes.
 - d. Click the **Statistics** tab and select the mean for each of the fluorescence parameters.

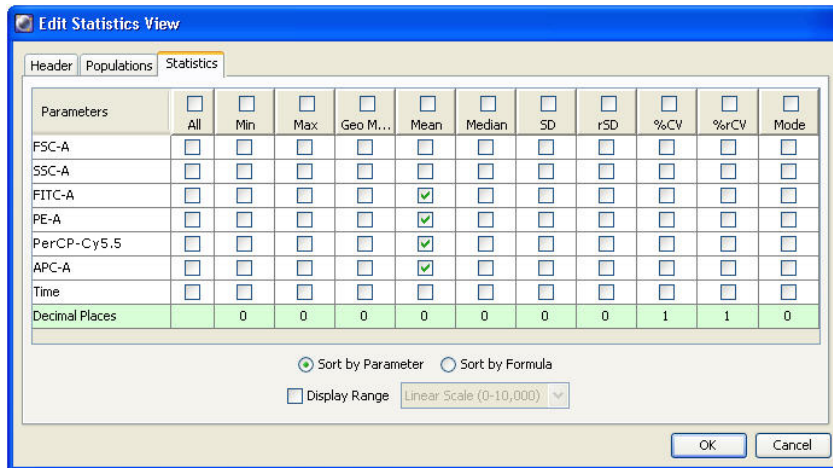

- e. Click **OK**.
12. Print the analysis.
 Your global worksheet analysis objects should look like the following.

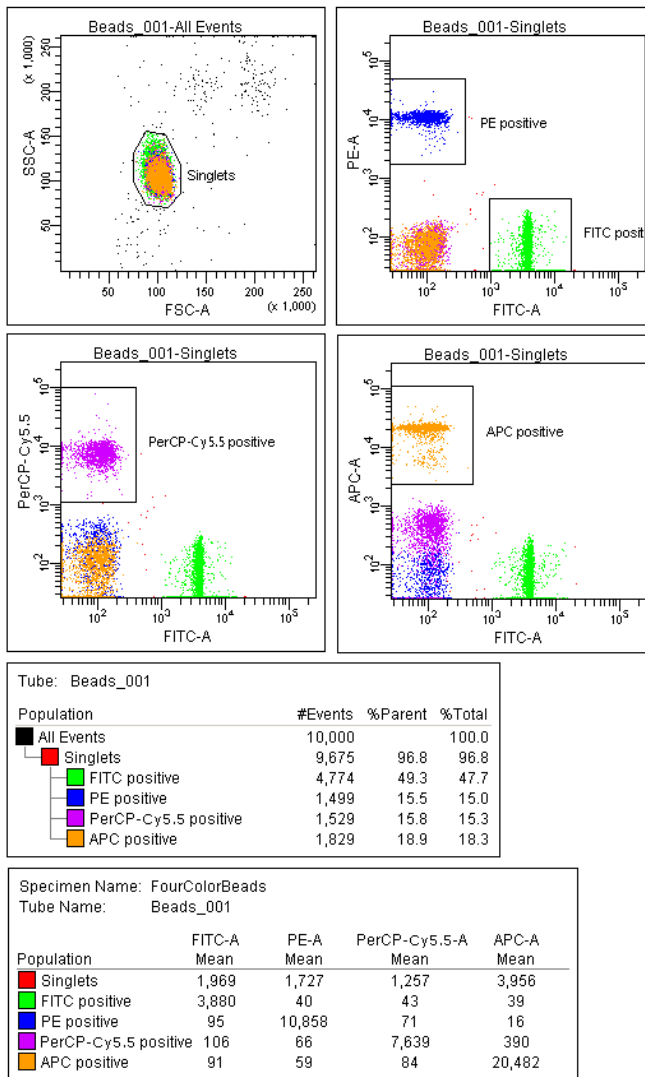

More information

- [Reusing an analysis \(page 84\)](#)

Reusing an analysis

Introduction

This topic describes how to use global worksheets to apply the same analysis to a series of recorded tubes. Once you define an analysis for a tube, you can use it to analyze the remaining tubes in the experiment. After viewing the data, print the analysis or save it to a normal worksheet.

Reusing an analysis

To reuse the analysis:

1. Set the current tube pointer to the *Beads_002* tube.
2. View the *Beads_002* data on your analysis worksheet. Adjust the gates as needed.

Adjustments apply to subsequent tubes viewed on the worksheet. To avoid altering a global worksheet, save an analysis to a normal worksheet, then make adjustments on the normal worksheet.

3. Print the analysis.

Saving the analysis

When you perform analysis with a global worksheet, the analysis does not save with the tube.

If you define your analysis on a global worksheet before recording data, you can specify to automatically save the analysis after recording data. You set this option in User Preferences.

To save a copy of the analysis with a tube:

1. Expand the *MyDataAnalysis* global worksheet icon in the **Browser**.
2. Right-click its analysis and select **Copy**.



3. Click the **Worksheets View** button on the Worksheet toolbar to switch to the normal worksheet view.
4. Select **Worksheet > New Worksheet** to create a new normal worksheet.
5. Right-click the *Beads_001* tube icon in the **Browser**, and select **Paste**.

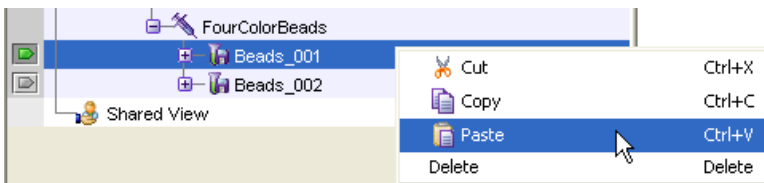

The analysis objects from the *MyDataAnalysis* global worksheet are copied to the *Beads_001_Analysis* normal worksheet. Double-click the *Beads_001* tube in the Browser to view the analysis.

Applying an analysis to normal worksheets

You can apply the global worksheet analysis to multiple tubes (on a single normal worksheet) by selecting multiple tubes before pasting the analysis. Ensure that you collapse all tube elements in the Browser before you paste them to multiple tubes.

More information

- [Analyzing data \(page 81\)](#)

This page intentionally left blank

8

Manual settings

This chapter covers the following topics:

- [About laser delay \(page 88\)](#)
- [Optimizing laser delay \(page 88\)](#)
- [Adjusting area scaling \(page 90\)](#)

About laser delay

Introduction

This topic describes how to manually set the laser delay if you are not using CS&T for cytometer setup and tracking.

About laser signal delay

Sample interrogation takes place within the cuvette flow cell. Laser light is directed through a series of prisms that focus multiple lasers on the event stream at different positions. This allows optimal detection of fluorescent signals from each laser with minimal cross-contamination from the other beams.

Because the laser signals are spatially separated, there is a slight delay between the detection of each laser's signal.

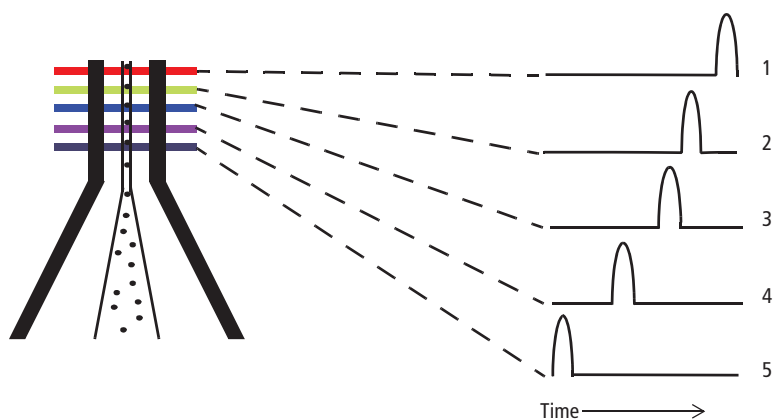

Item Number	Laser Delay
1	Red laser (longest) delay
2	Yellow-green laser delay
3	Blue laser delay
4	Violet laser delay
5	UV laser (shortest) delay

The laser delay setting in BD FACSDiva™ software is used to re-align the signals so they can be measured and displayed on the same time scale. Signals are aligned with respect to the blue laser, so the blue laser will have a 0 delay value, the red laser will have negative delay compensation, and the UV laser will have positive delay compensation.

Optimizing laser delay

Introduction

This topic describes how to optimize the laser delay using BD FACSDiva™ software.

Before you begin

To optimize the delay for a given laser, you must acquire events from a sample with a fluorescence signal excited by that laser. Follow the procedures in [Recording and analyzing data \(page 77\)](#), for sample optimization and acquiring data.

Procedure

To optimize laser delay:

1. While acquiring data from your sample, create a histogram to show the fluorescence signal excited by the laser for which the delay is to be optimized.
2. In the Acquisition Dashboard, set the **Events to Display** to **500** events.
3. Click the **Laser** tab in the **Cytometer** window.

Window extension and laser delay values are displayed in microseconds (μs).

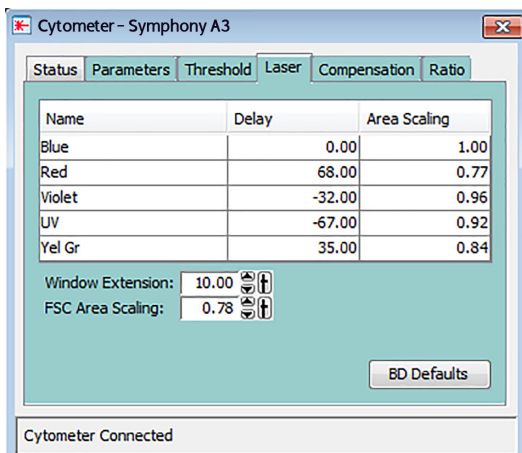

4. Set the **Window Extension** value to **0** μs .
5. Set an initial laser delay value **only** for the laser you are optimizing.
 - If you are optimizing the violet laser, set its delay to -35 μs .
 - If you are optimizing the UV laser, set its delay to -65 μs .
 - If you are optimizing the red laser, set its delay to 65 μs .
 - If you are optimizing the blue laser, set its delay to 0 μs .
 - If you are optimizing the yellow-green laser, set its delay to 35 μs .
6. While observing the positive events on the histogram, adjust the laser delay in 1 - μs increments. You might need to adjust the delay above or below the initial setting. Choose the setting that moves the events farthest to the right (highest fluorescence intensity).
7. Draw an interval gate on the histogram for the positive events.
8. Create a statistics view to display the mean fluorescence intensity (MFI) of the gated population.
9. While observing the MFI for the gated population, adjust the laser delay in 0.1 - μs increments within a range of 2.0 μs of the setting obtained in [While observing the positive events on the histogram, adjust the laser delay in \$1\$ - \$\mu\text{s}\$ increments. You might need to adjust the delay above or below the initial setting. \(page 89\)](#). Preserve the setting that maximizes the fluorescence intensity.
10. Reset the **Window Extension** to 10 μs .

Adjusting area scaling

Introduction

This topic describes how to manually adjust the area scaling on your cytometer if necessary for your application. The area scaling is automatically set in CS&T. Depending on the size of your target particle, you might need to adjust the area scaling manually. Larger particles are more likely to require an area scaling adjustment.

About area scaling

The area of a pulse is calculated by BD FACSDiva™ using measured height and width measurements. It is sometimes important to verify that the area calculation and the height measurement are equivalent by adjusting the factor applied to the area. The required area scaling factor changes based on sheath pressure and particle size.

About this example

The following example describes how to adjust area scaling for an experiment which uses only the 488-nm laser and the 640-nm laser. You must adjust area scaling for all lasers used in your experiment. To adjust the other lasers, add a parameter and the corresponding plots from that laser to the procedure.

Procedure

To adjust area scaling:

1. Open an existing experiment, or create a new experiment in the Browser.
2. Create a new specimen by clicking the **New Specimen** button on the Browser toolbar.
3. In the Inspector, click the **Parameters** tab and select the **H** checkbox to select the height for each parameter.

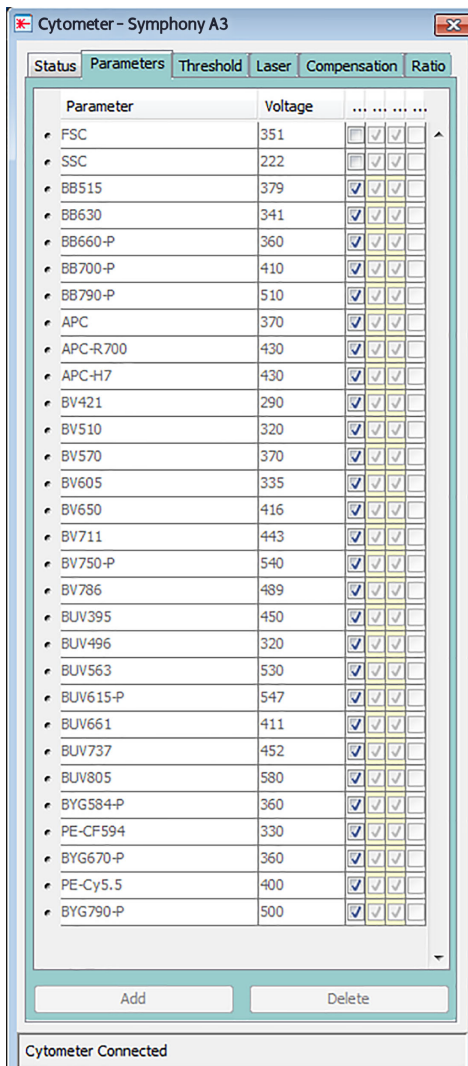

4. On the global worksheet, create the following plots and histograms:
 - FSC vs SSC dot plot
 - FSC-H and FSC-A histogram
 - FITC-H and FITC-A histogram
 - APC-H and APC-A histogram
5. Create a P1 gate in the FSC vs SSC plot, and show only the P1 population in all histograms.
6. Create three statistic views showing the following:
 - FSC-H and FSC-A means for P1
 - FITC-H and FITC-A means for P1
 - APC-H and APC-A means for P1

Your worksheet should look similar to the following figure.

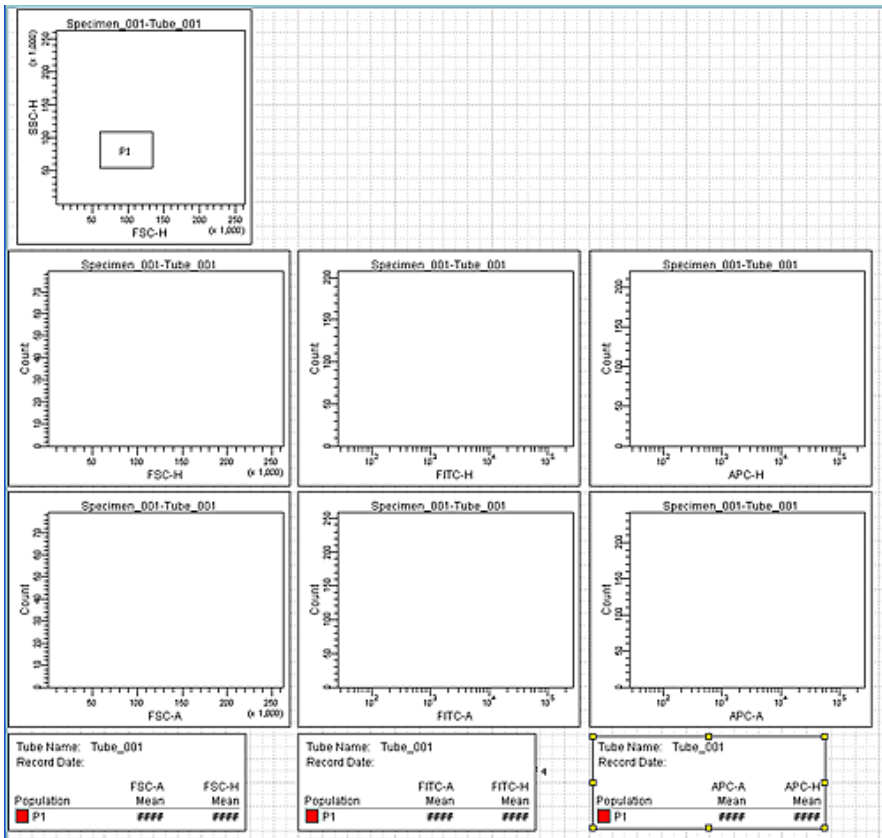

7. Expand the new specimen, then set the current tube pointer to *tube_001*.
8. Install the FITC-positive control tube onto the loading port and click **Load** in the Acquisition Dashboard.
9. Adjust the FSC and SSC voltages to place the particles on scale.

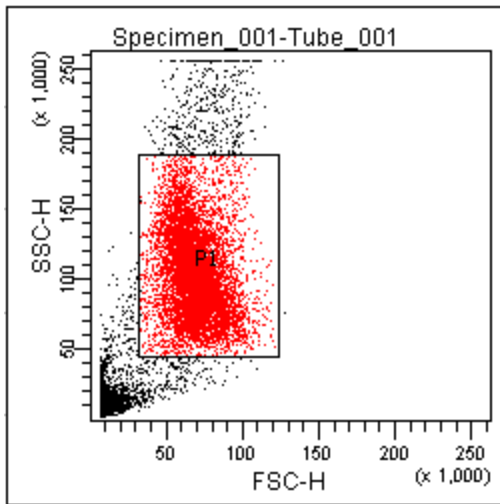

10. Adjust the P1 gate around the population of interest.
11. Adjust the FSC area scaling.
 - a. Click the **Laser Tab** in the Cytometer window.
 - b. Adjust the FSC area scaling factor until the FSC-A signal matches the FSC-H signal:

- Increase the area scaling factor if the FSC-A signal is lower than FSC-H.
- Decrease the area scaling factor if the FSC-A signal is higher than FSC-H.

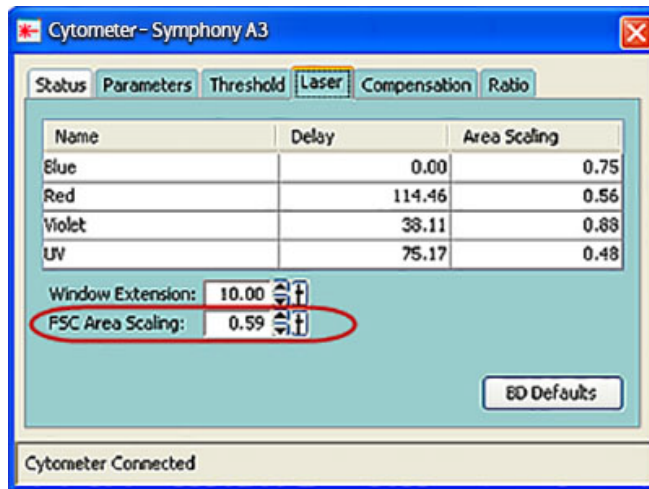

- View the result of your change in the histograms and statistics views.
- Adjust the blue laser area scaling factor until the FITC-A signal matches the FITC-H signal, if needed.
 - Unload the FITC-positive control tube, then load the APC-positive control tube.
 - Adjust the red laser area scaling factor until the APC-A signal matches the APC-H signal, if needed.

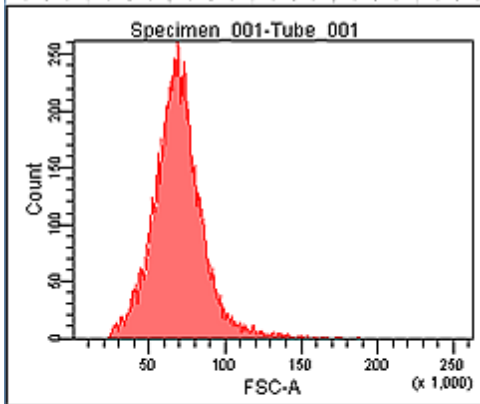
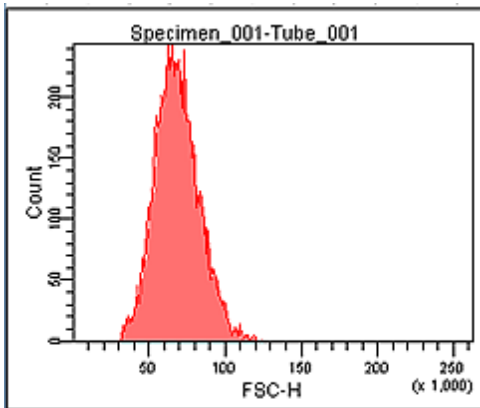

Tube Name: Tube_001		
Record Date: Dec 1, 2009 10:57:48 AM		
Population	FSC-A Mean	FSC-H Mean
■ P1	68,989	68,339

9

Troubleshooting

This chapter covers the following topics:

- [Cytometer troubleshooting \(page 96\)](#)
- [Electronics troubleshooting \(page 101\)](#)

Cytometer troubleshooting

Introduction

This topic describes possible problems and recommended solutions for BD FACSymphony™ A5 SE flow cytometer issues.

Droplets are visible on the SIP

Possible causes	Recommended solutions
Worn O-ring in the retainer	Replace the O-ring. See Changing the sample tube O-ring (page 44) .
Outer sleeve is not seated in the retainer	<ol style="list-style-type: none"> Loosen the retainer. Push the outer sleeve up into the retainer until seated. Tighten the retainer.
Outer sleeve is not on the sample injection tube	<p>Replace the outer sleeve.</p> <ol style="list-style-type: none"> Loosen the retainer. Slide the outer sleeve over the sample injection tube until it is seated. Tighten the retainer.
Waste line is pinched, preventing proper aspiration	Check the waste line.
Waste tank is full	Empty the waste tank.
Droplet containment vacuum is not functioning	Call your BD service representative.
The mode is not set to HTS.	Change the mode to HTS by pressing down the Mode button for more than 3 seconds.

Sample tube not fitting on SIP

Possible causes	Recommended solutions
Sample tube other than Falcon® tubes used	Use Falcon® 12 x 75-mm sample tubes. See Equipment (page 105) .
Worn Bal seal	Replace the Bal seal. See Changing the Bal seal (page 42) .
Sample tube is cracked	Transfer contents to a new tube.

Rapid sample aspiration

Possible causes	Recommended solutions
Support arm is to the side	Place the support arm under the sample tube.
Droplet containment module is failing	Try the solutions in Droplets are visible on the SIP (page 96) . If the issue is not resolved, call your BD service representative.

No events in acquisition display and RUN button is green

Possible causes	Recommended solutions
Threshold is not set to the correct parameter (usually FSC)	Set the threshold to the correct parameter for your application.
Threshold level is too high	Lower the threshold level.
PMT voltage for threshold parameter is set too low	Set the PMT voltage higher for the threshold parameter.
Gating issue	See the <i>BD FACSDiva™ Software Reference Manual</i> for information on setting gates.
Air in the sheath filter	Purge the filter. See Removing air bubbles (page 27) .
Air bubble or debris in the flow cell	Prime the fluidics system. See Preparing the fluidics (page 31) .
No sample in the tube	Verify that sample remains in the tube and if necessary, add sample to the tube or install a new sample tube.
Sample is not mixed properly	Mix the sample to suspend the cells.
Waste tank is full	Empty the waste tank.
PMT voltages set too low or too high for display parameter	Adjust the PMT voltages.
Too few events are displayed	Increase the number of events to display.
Sample injection tube is clogged	Remove the sample tube to allow backflushing. If the event rate is still erratic, clean the sample injection tube. See Cleaning the fluidics (page 37) .
Bal seal is worn	Replace the Bal seal. See Changing the Bal seal (page 42) .
Instrument is not warmed up	Wait 30 minutes for the instrument to warm up.
Laser delay is set incorrectly	Adjust the laser delay settings. See Manual settings (page 87) .
Laser is not functioning	Verify the malfunction by changing the threshold to an alternative laser while running the appropriate sample. If unsuccessful, contact BD Biosciences.
Tube is cracked or misshapen	Replace the sample tube.

No events in acquisition display and RUN button is orange

Possible causes	Recommended solutions
RUN is not activated	Press the RUN button.
Sample tube is not installed or is not properly seated	Install the sample tube correctly on the SIP.
Sample tube is cracked	Replace the sample tube.
Waste tubing line is disconnected from the waste container tank	Connect the waste tubing line to the waste container tank.
Sheath container is not pressurized	<ul style="list-style-type: none"> • Ensure that the sheath container lid and all connectors are securely seated. • Inspect the sheath container O-ring inside the lid and replace it if necessary. See Cleaning or replacing the sheath gasket (page 45)
Bal seal is worn	Replace the Bal seal. See Changing the Bal seal (page 42) .
Air leak at sheath container	Ensure that the sheath container lid and all connectors are securely seated.
Sheath container is empty	Fill the sheath container.
Air in sheath filter	Purge the filter. See Removing air bubbles (page 27) .

No fluorescence signal

Possible causes	Recommended solutions
Incorrect fluorochrome assignment	Make sure that the cytometer configuration in the software matches the optical filters in the cytometer and the configuration is as expected.
Laser is not functioning	Call your BD service representative.

No signal in red laser channels (when red laser is installed)

Possible causes	Recommended solutions
Incorrect laser delays due to a change in the sheath tank fluid level	<ul style="list-style-type: none"> • Check the fluid level in the sheath tank and refill if necessary. • Adjust the laser delay settings. See Manual settings (page 87).

High event rate

Possible causes	Recommended solutions
Air bubbles in the sheath filter or flow cell	Remove the air bubbles. See Removing air bubbles (page 27) .
Threshold level is too low	Increase the threshold level. See the <i>BD FACSDiva™ Software Reference Manual</i> for instructions.
PMT voltage for the threshold parameter is set too high	Set the PMT voltage lower for the threshold parameter. See the <i>BD FACSDiva™ Software Reference Manual</i> for instructions.
Sample is too concentrated	Dilute the sample.
Sample flow rate is set to HIGH	Set the sample flow rate to MED or LOW.

Low event rate

Possible causes	Recommended solutions
Threshold level is too high	Lower the threshold level. See the <i>BD FACSDiva™ Software Reference Manual</i> for instructions.
Air bubble or debris in the flow cell	Prime the fluidics system. See Preparing the fluidics (page 31) .
PMT voltage for the threshold parameter is set too low	Set the PMT voltage higher for the threshold parameter. See the <i>BD FACSDiva™ Software Reference Manual</i> for instructions.
Sample is not adequately mixed	Mix the sample to suspend the cells.
Sample is too diluted	Concentrate the sample. If the flow rate setting is not critical to the application, set the flow rate switch to MED or HIGH.
Sample injection tube is clogged	Remove the sample tube to allow backflushing. If the event rate is still erratic, clean the sample injection tube. See Cleaning the fluidics (page 37) .

Erratic event rate

Possible causes	Recommended solutions
Sample tube is cracked	Replace the sample tube.
Air bubble or debris in the flow cell	Prime the fluidics system. See Preparing the fluidics (page 31) .
Bal seal is worn	Replace the Bal seal. See Changing the Bal seal (page 42) .
Sample injection tube is clogged	Remove the sample tube to allow backflushing. If the event rate is still erratic, clean the sample injection tube. See Cleaning the fluidics (page 37) .
Contaminated sample	Prepare the specimen again. Ensure that the tube is clean.
Sheath filter is dirty	Replace the filter. See Changing the sheath filter (page 41) .

Distorted scatter parameters

Possible causes	Recommended solutions
Cytometer settings are improperly adjusted	Optimize the scatter parameters. See the <i>BD FACSDiva™ Software Reference Manual</i> for instructions.
Air bubble in the sheath filter or flow cell	Purge the air from the filter. See Removing air bubbles (page 27) .
Flow cell is dirty	Flush the system. See Flushing the system (page 38) .
Air leak at sheath container	Ensure that the sheath container lid is tight and all connectors are secure.
Hypertonic buffers or fixative	Replace the buffers or fixative.

Excessive amount of debris in display

Possible causes	Recommended solutions
Threshold level is too low	Increase the threshold level.
Sheath filter is dirty	Replace the filter. See Changing the sheath filter (page 41) .
Flow cell is dirty	Flush the system. See Flushing the system (page 38) .
Dead cells or debris in the sample	Examine the sample under a microscope.
Sample is contaminated	Re-stain the sample. Ensure that the tube is clean.
Stock sheath fluid is contaminated	Rinse the sheath container with DI water, then fill the container with sheath fluid from another (or new lot) bulk container.

High CV or poor QC results

Possible causes	Recommended solutions
Air bubble in sheath filter or flow cell	<ul style="list-style-type: none"> Purge the filter. See Removing air bubbles (page 27). Prime the fluidics system. See Preparing the fluidics (page 31).
Sample flow rate is set too high	Set the sample flow rate lower.
Air leak at sheath container	Ensure that the sheath container lid is tight and all connectors are secure.
Flow cell is dirty	Flush the system. See Flushing the system (page 38) .
Waste tank is pressurized	Replace the waste container cap. See Replacing the waste container cap (page 40) .
Poor sample preparation	Repeat sample preparation.
Sample was not diluted in the same fluid as the sheath fluid	Dilute the sample in the same fluid as you are using for sheath.
Old or contaminated QC particles	Make new QC samples and perform the quality control procedure again.
Instrument is not warmed up	Wait 30 minutes for the instrument to warm up.
Laser is not functioning	Contact BD Biosciences.
Optical alignment problem	Contact BD Biosciences.

Carryover from previous sample observed

Possible causes	Recommended solution
Residual sample in sample injection tube or fluidic system from previous tests	Clean the sample injection tube and, if carryover is still observed, clean the fluidics (see Cleaning the fluidics (page 37)).

Electronics troubleshooting

Introduction

This topic describes possible problems and recommended solutions for electronics issues.

“Cytometer Disconnected” in cytometer window

Possible causes	Recommended solutions
Cytometer power is off	Turn on the cytometer main power.
Communication failure between workstation and cytometer	<ol style="list-style-type: none"> In BD FACSDiva™ software, select Cytometer > Connect. If connecting does not work, restart the cytometer. Turn the cytometer off, wait 1 minute, and turn on the cytometer main power. If connecting still does not work, contact BD Biosciences.

10

Supplies and consumables

This chapter covers the following topics:

- [Ordering information \(page 104\)](#)
- [Beads \(page 104\)](#)
- [Reagents \(page 105\)](#)
- [Equipment \(page 105\)](#)

Ordering information

To order spare parts and consumables from BD Biosciences:

- Within the US, call (877) 232-8995.
- Outside the US, contact your local BD Biosciences customer support representative.

Worldwide contact information can be found at bdbiosciences.com.

Beads

Introduction

This topic lists the QC and CS&T beads available.

QC particles

Particle	Laser	Supplier	Catalog No.
SPHERO™ Rainbow Calibration Particles (8 peaks)	All	BD Biosciences	559123
SPHERO™ Ultra Rainbow Fluorescent Particles (single peak)	All	Spherotech, Inc.	URFP-30-2
BD® DNA QC Particles	Blue (488 nm)	BD Biosciences	349523

CS&T beads

Bead	Laser	Supplier	Catalog No.
BD® Cytometer Setup and Tracking Beads for BD FACSDiva™	<ul style="list-style-type: none"> • UV (355 nm) • Violet (405 nm) • Blue (488 nm) • Red (637 nm) • Yellow-green (561 nm) 	BD Biosciences	<ul style="list-style-type: none"> • 641319 (50 tests) • 642412 (150 tests)

Reagents

Reagent	Supplier	Catalog No.
BD FACST [™] Flow™ sheath fluid	BD Biosciences	342003
BD FACS [™] Sheath Solution with surfactant (recommended for use with the HTS option)	BD Biosciences	336524
Monoclonal antibodies	BD Biosciences	See the BD Biosciences Product Catalog or the BD Biosciences website (bdbiosciences.com)
BD FACS [™] Lysing solution	BD Biosciences	349202
BD [®] Detergent Solution Concentrate	BD Biosciences	660585
BD FACSClean [™]	BD Biosciences	340345
Dyes and fluorochromes	BD Biosciences, Life Technologies, or Sigma	–
Chlorine bleach (5% sodium hypochlorite)	Clorox [®] or other major supplier (to ensure that the bleach is at the correct concentration and free of particulate matter)	–

Equipment

Equipment item	Supplier	Catalog No.
Bal seal	BD Biosciences	343509
O-ring, sample tube		343615
Sheath filter assembly		34364507
Waste tank caps , pack of 12		338854
Baffle SPA 10L waste tank ext		338505
Falcon [®] polystyrene test tubes, 12 x 75-mm	Corning	352008

This page intentionally left blank

A

- acridine orange (AO) 37
- air bubbles, removing 27
- alarm
 - waste container 19
- analysis
 - data 78
 - immunophenotyping 81
 - reusing 84
 - saving 85
- AO See acridine orange 37
- application settings
 - applying 79
 - creating 72
- area scaling 90
- arm, tube support 18
- aspiration (sample), rapid 96
- assistance, technical 10
- autofluorescence 52

B

- Bal seal
 - ordering 105
 - replacing 42
- BD detergent solution 37
- BD FACSClean solution 105
- BD FACSDiva software See software 8
- BD FACSFlow sheath fluid 105
- BD FACSFlow solution 27
- BD FACSFlow supply system 24, 38
- BD High Throughput Sampler (HTS) 18
- bleach 36, 105
- bubbles, removing air 28
- buttons
 - fluid control 15
 - sample flow rate control 16

C

- calculating compensation 76
- capacity, waste container 19
- cleaning solutions 36
- compensation
 - calculating 76
 - control tubes 73
 - recording settings 74
- compensation controls 56
- components
 - sheath container shown 26
 - sheath filter shown 41
 - waste container shown 30
- computer system, about 22
- configuration
 - BD FACSDiva 65
- containers
 - sheath 19, 25
 - waste 19, 29, 31
- control
 - single-stained 65, 78
- control panel, cytometer 14
- controls
 - fluidics 14
- conventions
 - safety symbols 8
- creating
 - analysis objects 81
 - global worksheets 78
 - statistics view 81
- CS&T particles 104
- cuvette flow cell 88
- CV, troubleshooting 101
- cytometer 12
 - configuration 65
 - disconnect error 102
 - setup 64

- starting 24
- troubleshooting 96

D

- DAPI, cleaning after using 37
- data
 - analyzing 78, 81
 - gating 81
 - recording 78-79
- debris, excessive 100
- delay, laser 88
- detector arrays 20
- detector parameters 49
- detectors 21
- detergent solution 37
- digital data 12
- Diva software See software 8
- droplet containment system 19

E

- electronics
 - troubleshooting 101
- event rate
 - erratic 99
 - high 99
 - low 99
 - zero 97-98
- excessive debris 100
- experiments
 - creating 69
 - immunophenotyping 78
 - sample optimization 69
 - specifying parameters 70

F

- FACSFlow sheath fluid [f] 105
- FACSFlow solution[f] 27
- Falcon tubes 96
- filters, sheath
 - attaching new 42
 - replacing 41
- fixed-alignment lasers 12

- flow cell
 - draining 31
- flow rate control buttons 16
- fluid control buttons
 - PRIME 15
 - RUN 15
 - STANDBY 15
- fluidics
 - description 15
 - flow rate control 16
 - flushing system 38
 - priming 31
 - removing air bubbles 28
 - run mode 15
 - sample injection port (SIP) 17-18
- fluidics controls, cytometer 14
- fluidics interconnect 29
- fluorescence signal, none 98
- flushing the system 38

G

- gating data 81
- global worksheets
 - analyzing data 81
 - creating 78
 - previewing data 78, 84

H

- hazard symbol definitions 8
- High Throughput Sampler (HTS) 18

I

- immunophenotyping
 - analysis 81
 - experiment 78

L

- laser channels 48
- laser delay
 - about 88
 - optimizing 89

lasers
 options 20
 performance check 67
 quality control (QC) particles 104

M

maintenance
 Bal seal 42
 cytometer shutdown 38
 sample tube O-ring 44
 schedule 36
 scheduled 38
 sheath filter 41
 system flush 38

O

O-ring
 ordering 105
 replacing 44
 worn 96

optics
 components 20
 configuration 65-66
 filters 20

optimization, sample 64

ordering
 waste tank baffle 105

ordering spare parts 104

P

parameter labeling 54
 particles 104
 performance check 67
 photodiode 21
 photomultiplier tubes (PMTs) 21
 PMT See photomultiplier tubes 21
 population hierarchy 81
 primary detector allocations 52
 PRIME, fluid control button 15
 priming fluidics system 31
 propidium iodide (PI) 37

Q

quality control (QC)
 particles 104
 troubleshooting 101

R

recording
 compensation settings 74
 compensation tubes 73
 data 78-79

removing air bubbles, filter 28

replacing
 Bal seal 42
 sample tube O-ring 44
 sheath filter 41
 waste air filter 40, 45

reusing analyses 84

RUN
 button orange 98
 fluid control button 15

S

safety symbol definitions 8
 safety symbols 8

sample
 optimization 64
 optimization experiment 69
 optimization, single-stained control 65, 78

sample injection port (SIP)
 components 17-18
 replacing Bal seal 42
 replacing sample tube O-ring 44

sample tube
 injection 18
 not fitting 96
 requirements 96

samples, running 79

saving analyses 85

scatter
 parameter distortion 100

setup, cytometer 64

- sheath container
 - components shown 26
 - defined 19
 - depressurize 26
 - preparing 26
- sheath filter
 - components shown 41
 - ordering 105
 - removing air bubbles 27
 - replacing 41
- sheath fluid
 - backflush 19
 - BD FACFlow sheath fluid 105
- signals, amplifying 21
- single-color controls 57
- single-stained control 48, 52-53, 75-76
- single-stained setup 58
- software
 - cytometer control 8
 - version 22
- spare parts, ordering 104
- Spectral 47
- spectral experiment setup 53
- spectral functions
 - overview 48
- spectral unmixing 52, 56
- STANDBY, fluid control button 15
- starting cytometer 24
- statistics views 81
- support, technical 10

T

- technical assistance 10
- thiazole orange (TO) 37
- TO See thiazole orange 37
- troubleshooting
 - cytometer 96
 - electronics 101
- tubes
 - Falcon 96
 - requirements 96

U

- user preferences 66

W

- waste air filter
 - component shown 30
- waste container 19
 - alarm 19
 - capacity 19
 - components shown 30
 - defined 19
 - emptying 29
- waste tank baffle
 - ordering 105
- waste tank caps
 - ordering 105
- window extension 89
- workstation, about 22

Becton, Dickinson and Company
BD Biosciences
2350 Qume Drive
San Jose, CA 95131 USA

BD Biosciences
European Customer Support
Tel +32.53.720.600
help.biosciences@bd.com

bdbiosciences.com
ResearchApplications@bd.com